

Bulletin
8F 7/11
Style W

BELT DRIVE AIR HANDLERS 2 Thru 30 Tons

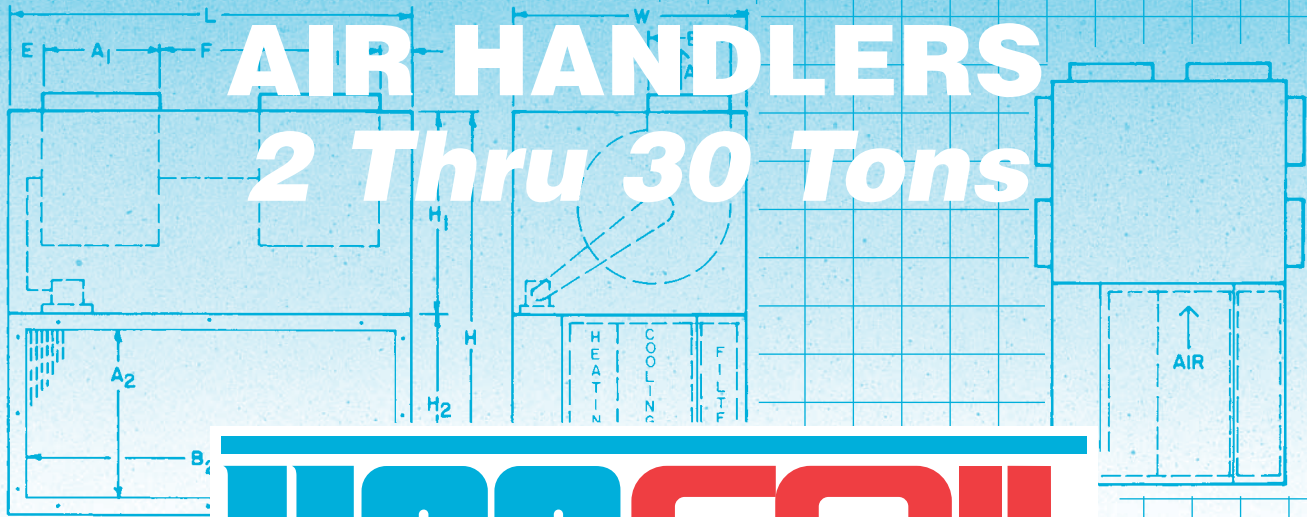

USA COIL & AIR

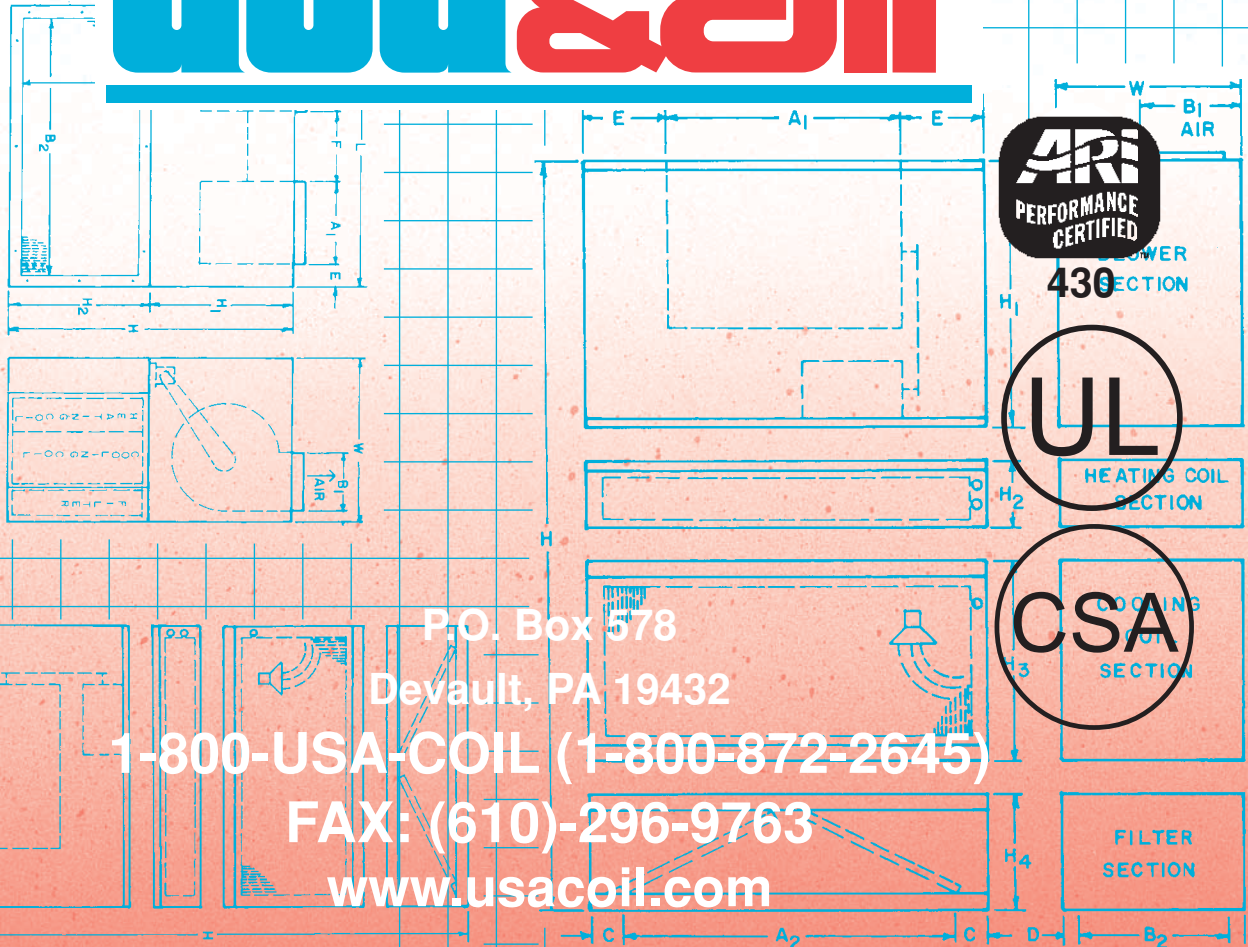

P.O. Box 578
Devault, PA 19432

1-800-USA-COIL (1-800-872-2645)

FAX: (610)-296-9763

www.usacoil.com

Air Handling Units: Fast Shipment, excellent quality, and economical- all at USA Coil & Air



A lot of jobs don't require a full-fledged Central Station Air Handling Unit. USA Coil & Air builds a line of stock Belt Drive Air Handling Units that can be used for almost any "commercial" application that you might run across. Do you have a shopping mall where you need a variety of units in a hurry? Do you have a restaurant where you need

a DX Unit by next week? How about a Chilled Water Unit for a hotel, school, dormitory or small office building? There are a huge number of applications where your Air Handling Unit needs to be reliable and of good construction, but it doesn't have to be "state the art" technology either. You need a unit next week and certainly can't wait 8 to 10 weeks. You want to pay the right amount of money for the proper unit, but the job just doesn't qualify for the best unit in the HVAC Industry. USA offers Belt Drive Units that give you an economical, well-constructed, efficient alternative to a large Central Station Unit or a less expensive Fan/Coil Unit.

We stock Horizontal Units in 11 sizes up to 30 tons, and we stock Vertical Units in 11 sizes up to 20 tons. We can give you a Chilled Water Unit or a DX Unit. We can add Hot Water Coils to any unit, as well as Discharge Grilles, Mixing Boxes and assorted other accessories. We offer you a great unit at economical prices and, we ship it out of stock! What more could you possibly ask for?

Tom Jacobs

Tom Jacobs
President

As you've probably noticed by now, the "big" companies in our industry are not exactly responsive to customers on small jobs. The HVAC industry seems to get more "production" oriented every year, and unless you have a big job, the big companies don't exactly go out of their way to help you. USA Coil & Air is different. We're not

a "big" company, and we do get our business from a lot of small jobs. With this in mind, we developed a line of units designed specifically for all the small commercial applications that you might see. We've really tried to blend quality, economics and service into our Belt Drive Air Handling Units. Maybe you can buy another unit for a few dollars less, but how does that help you if you can't get it for 3 months? Maybe there are units with slightly better quality, but can you afford to spend megabucks to buy the unit? Maybe you can find another unit in stock, but will it do what you want it to do?

USA is set up to meet the demands of the HVAC Industry and there is a large demand for our Belt Drive Air Handling Units. We hope you will give us a call at your earliest opportunity!

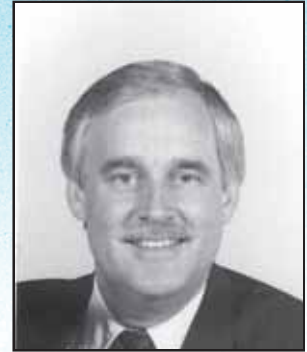

Bob Jacobs

Bob Jacobs
Vice President

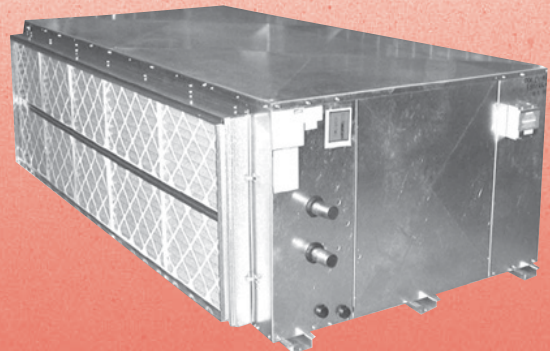

TABLE OF CONTENTS

Section	Description	Page
Shipment Options Description, Features & Specifications	Shipment Options	4
	Specifications, Description & Nomenclature	5-6
	Cooling Capacities	7-9
	Heating Capacities	10
	Sound Power Levels	11
	Motor Data	12
Horizontal Units Dimensional Drawings	Horizontal 2 thru 5 tons	13
	Horizontal 7.5 tons	14
	Horizontal 10 thru 30 tons	15
Optional Section	Angular Filter Section - Horizontal Units	16-18
Vertical Units Dimensional Drawings	Vertical 2 thru 7.5 tons	19
	Vertical 10 thru 30 tons	20
Optional Section	Angular Filter Section - Vertical Units	21-22
Mixing Boxes	All Horizontal and Vertical Units	23
Duct Integral Heater	Duct Integral Heater 2 thru 7.5 tons	24
	Duct Integral Heater 10 thru 30 tons	25
Miscellaneous	Weights & Measures	26
	Piping Instructions	27

Replacement Engineering Made Easy.



1-800-USA-COIL
(1-800-872-2645)

FAX: (610) 296-9763

11 Horizontal & 11 Vertical Units with 3 Shipment Options



Horizontal Chilled Water Unit
2 thru 30 tons
800 thru 12,000 CFM



Vertical Chilled Water Unit.
2 thru 30 tons
800 thru 12,000 CFM

10 WORK DAY SHIPMENT - ALL SIZES

USA Coil & Air builds 11 different sizes of horizontal and vertical units available to ship in 10 days. Almost all options are available under this program. There is a premium to ship using this program and often is for emergencies or replacement jobs.

4 WEEK SHIPMENT (20 WORK DAY)

USA Coil & Air also ships the same equipment under a 4 week ship program. The premium for this is less than the 10 work day program. This option is often used for design/build jobs where there is some urgency, but immediate shipment is not required.

STANDARD SHIPMENT (7-8 WEEKS NORMAL)

USA Coil & Air offers this schedule for the lowest pricing where quick shipment is not required.

SPECIFICATION GUIDE

Three-pound density neoprene coated fiberglass. Insulation covers interior of cabinet. Optional 1" fiberglass insulation, double wall (Solid or Perforated), 1/2"-1" foil-face and elastomeric insulation.

Heavy-Gauge Galvanized Steel Cabinet

Filter Access Clip (See detail below)

Two-inch Pleated Filter 30/30 Efficiency Standard

Single (800-3000) or Double (4000-12,000) Blower Assembly with Forward-Curved Fans

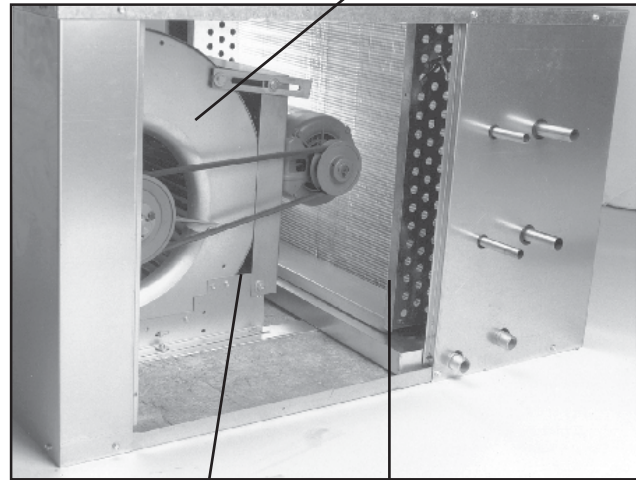
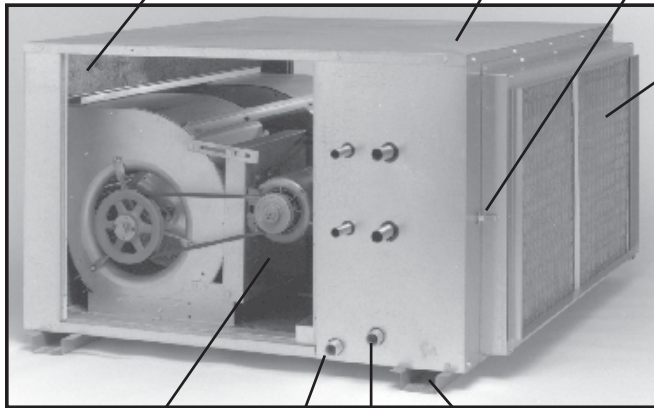

Motor and Drive Selections Accommodating 800 to 12,000 CFM. Factory installed and Adjusted to Meet CFM & T.S.P. Requirements. Severe duty, high temperatures, TEFC-Optional.

Secondary Drain Connection

Primary Drain Connection

Mounting Channels 3000 to 12,000 CFM (Optional on 800 to 2000 CFM)

Heavy-Duty Adjustable Motor Mount

Two- or Four-Pipe, 1/2" O.D. Copper Coil with Aluminum Fins, spaced at 12 F.P.I. Up to ten-rows any combination of cooling, heating, DX and Steam.



Standard Spring-Loaded Clips on each side for easy filter access without the use of tools.



STANDARD FEATURES

Cabinet – Heavy-gauge galvanized steel insulated with 1/2" thick, over three pound density, neoprene coated fiberglass.

Coils – 1/2" OD copper tube with aluminum fins (12 FPI) equipped with manual-air vent. Coils are 100% underwater pressure tested at 350 PSI with a 300 PSI working pressure.

Drain Pan – Galvanized and powder coated epoxy with a 1/4" thick closed-cell insulation and has primary and secondary drain connections.

Blower & Assembly – Belt-driven draw-through design with forward-curved and dynamically balanced blowers. Adjustable, variable-pitch drive sheave and cast-iron pulley keyed to motor shaft.

Controls – Controls and motors are factory-wired and

terminated in a junction box for single-point power supply.

Filter – Two-inch thick, 30/30 pleated filter, flatly mounted, with spring loaded clips on each side of the access door for easy maintenance without the use of tools.

Added Features – Each unit is tagged and crated as scheduled for installation.

Certification – UL and cUL approved, ARI certified and 100% factory tested.

OPTIONAL FEATURES

Cabinet – Soft-white, powder-coated epoxy cabinet. Deluxe, Weatherproof, Deluxe-Weatherproof, Double-Wall (Solid or Perforates) and Top or Bottom Supply.

Drain Pans – Stainless steel and double-wall.

Coils – Copper fins, phenolic coated, stainless-steel end plates. All options are available on one to ten rows.

Insulation – fiberglass, foil-faced, elastomeric and double-wall (solid or perforated) in 1/2" and 1" thickness.

Systems – Two or Four-pipe, Hydronic cooling/heating, Steam, Direct-expansion (DX) and/or Electric Heat.

Controls – Unlimited selection of factory-mounted valves, controls and enclosures.

Motors - severe-duty, high temperature, ODP, TEFC; 115, 208, 230, 277, 460, 575 voltages.

Filters – Two-inch thick throwaway, washable and V-Bank.

Electric Heat – Electric Resistance Heaters from 1 to 65 kW

Mixing Boxes - With dampers, modulating and three-position economizers.

NOMENCLATURE

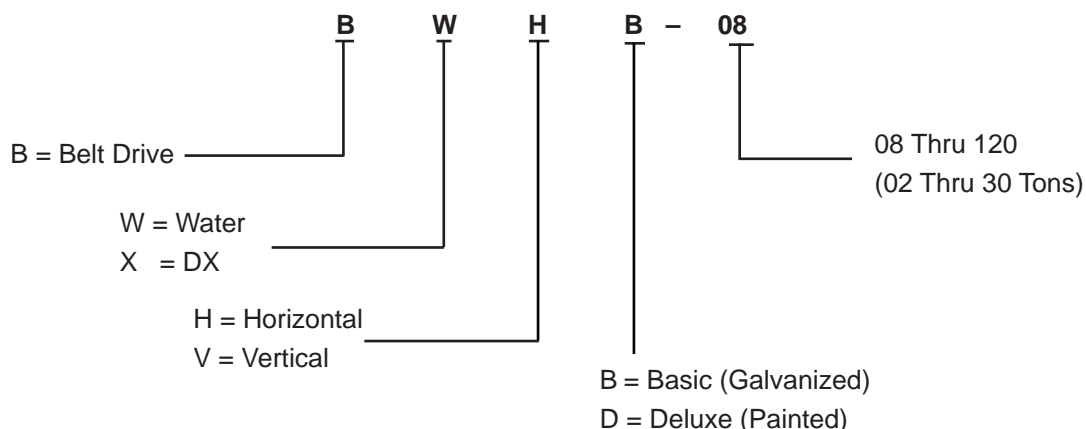

COOLING CAPACITIES ALL HORIZONTAL & VERTICAL UNITS - EWT: 40°F & 42°F

COOLING CAPACITIES FOR WATER TEMPERATURE RISE 10° - 80°F DB/67°F WB																	
SIZE	ROWS	CIR.	CFM	ENTERING WATER TEMPERATURE 40°							ENTERING WATER TEMPERATURE 42°						
				TOTAL BTU	SENS BTU	GPM	WPD	APD	GPM/CIR.	TUBE VEL.	TOTAL BTU	SENS BTU	GPM	WPD	APD	GPM/CIR.	TUBE VEL.
08	4	3	800	37.5	24.6	7.9	9.6	0.631	2.6	4.5	33.8	23.1	7.1	7.8	0.615	2.4	4.0
	6	7	800	41.0	26.7	8.6	2.2	0.922	1.2	2.1	37.3	25.3	7.9	1.8	0.906	1.1	1.9
	8	7	800	48.6	30.4	10.1	3.6	1.248	1.4	2.5	44.5	28.6	9.3	3.1	1.231	1.3	2.3
12	4	7	1200	48.9	33.9	10.3	2.6	0.658	1.5	2.5	44.1	32.2	9.3	2.1	0.641	1.3	2.3
	6	7	1200	65.9	42.2	13.9	5.0	1.012	2.0	3.4	59.9	39.6	12.5	4.1	0.994	1.8	3.0
	8	7	1200	76.0	46.9	16.0	8.2	1.361	2.3	3.9	70.1	44.2	14.8	7.1	1.346	2.1	3.6
16	4	7	1600	72.8	48.7	15.4	5.0	0.626	2.2	3.7	65.5	45.1	13.7	4.0	0.610	2.0	3.3
	6	7	1600	93.7	58.5	19.6	10.8	0.951	2.8	4.7	85.8	55.1	18.1	9.2	0.937	2.6	4.4
	8	7	1600	105.9	64.9	22.1	16.4	1.275	3.2	5.4	97.8	61.1	20.5	14.9	1.260	2.9	5.0
20	4	8	2000	87.6	58.7	18.3	5.6	0.715	2.3	3.9	79.4	55.7	16.7	4.7	0.699	2.1	3.5
	6	16	2000	100.1	65.9	21.1	2.7	1.057	1.3	2.2	91.0	61.9	19.2	2.3	1.037	1.2	2.0
	8	16	2000	119.0	74.6	24.9	3.2	1.431	1.6	2.6	109.3	70.2	23.0	2.8	1.412	1.4	2.4
30	4	10	3000	142.2	93.5	30.0	9.8	0.654	3.0	5.1	129.4	87.7	27.4	8.3	0.640	2.7	4.6
	6	15	3000	171.0	107.6	36.0	6.3	0.977	2.4	4.1	156.4	101.2	33.0	5.4	0.961	2.2	3.7
	8	15	3000	194.7	119.5	40.9	9.6	1.310	2.7	4.6	179.8	112.5	37.9	8.3	1.295	2.5	4.3
40	4	20	4000	170.9	115.9	35.9	2.7	0.658	1.8	3.0	154.3	110.1	32.6	2.2	0.642	1.6	2.8
	6	30	4000	208.3	136.2	43.7	2.4	0.989	1.5	2.5	189.7	128.0	39.9	2.0	0.972	1.3	2.3
	8	30	4000	246.4	153.6	52.2	3.7	1.338	1.7	2.9	224.8	143.1	47.1	3.1	1.318	1.6	2.7
50	4	20	5000	227.2	150.3	48.1	5.2	0.664	2.4	4.1	204.5	141.1	42.9	4.2	0.648	2.1	3.6
	6	30	5000	274.8	175.7	58.1	3.4	0.994	1.9	3.3	249.4	165.2	52.2	3.6	0.976	1.7	2.9
	8	30	5000	316.9	195.6	66.9	5.3	1.337	2.2	3.8	292.2	184.1	61.9	4.6	1.322	2.1	3.5
60	4	20	6000	282.4	184.7	59.7	7.5	0.667	3.0	5.1	257.1	175.5	54.4	6.3	0.653	2.7	4.6
	6	30	6000	339.6	215.2	71.5	5.6	0.997	2.4	4.0	311.2	202.3	65.8	4.8	0.982	2.2	3.7
	8	30	6000	388.3	239.1	81.5	8.5	1.339	2.7	4.6	358.6	225.0	75.6	7.3	1.323	2.5	4.3
80	4	26	8000	379.3	249.2	79.9	8.6	0.666	3.1	5.2	344.6	234.0	73.0	7.3	0.652	2.8	4.8
	6	39	8000	455.2	286.9	95.8	5.8	0.994	2.5	4.2	417.3	269.8	88.0	5.0	0.979	2.3	3.8
	8	52	8000	504.0	313.0	106.3	4.6	1.325	2.0	3.5	463.2	291.8	98.3	4.0	1.308	1.9	3.2
100	4	26	10000	493.1	318.8	103.5	15.0	0.664	4.0	6.7	448.5	299.4	94.6	12.6	0.650	3.6	6.2
	6	52	10000	565.0	358.6	119.0	5.3	0.980	2.3	3.9	517.6	337.2	109.5	4.5	0.965	2.1	3.6
	8	52	10000	646.0	398.4	135.8	8.3	1.315	2.6	4.4	596.9	375.1	125.9	7.2	1.301	2.4	4.1
120	4	52	12000	512.0	347.7	107.5	3.6	0.726	2.1	3.5	463.2	330.3	97.6	3.0	0.709	1.9	3.2
	6	52	12000	674.9	426.0	142.2	7.8	1.110	2.7	4.6	618.7	404.7	130.9	6.7	1.093	2.5	4.3
	8	52	12000	772.7	473.8	162.3	12.3	1.491	3.1	5.3	713.2	446.0	150.4	10.6	1.473	2.9	4.9

SYMBOLS: GPM: Gallons of water per minute
 WPD: Water pressure drop in feet of water
 APD: Air Pressure Drop

Cooling Capacities

Horizontal & Vertical

COOLING CAPACITIES - ALL HORIZONTAL & VERTICAL UNITS - EWT: 45°F & 50°F

COOLING CAPACITIES FOR WATER TEMPERATURE RISE 10° - 80°F DB/67°F WB																	
SIZE	ROWS	CIR.	CFM	ENTERING WATER TEMPERATURE 45°							ENTERING WATER TEMPERATURE 50°						
				TOTAL BTU	SENS BTU	GPM	WPD	APD	GPM/CIR.	TUBE VEL.	TOTAL BTU	SENS BTU	GPM	WPD	APD	GPM/CIR.	TUBE VEL.
08	4	3	800	28.7	21.3	6.0	5.8	0.590	2.0	3.4	20.8	18.3	4.4	3.6	0.533	1.5	2.5
	6	7	800	31.5	22.8	6.6	1.3	0.872	0.9	1.6	22.8	19.6	4.8	1.1	0.795	0.7	1.2
	8	7	800	38.3	25.9	8.1	2.3	1.199	1.2	2.0	27.9	21.7	5.9	1.3	1.114	0.8	1.4
12	4	7	1200	36.8	29.3	7.7	1.5	0.609	1.1	1.9	25.7	25.7	5.5	0.8	0.467	0.8	1.3
	6	7	1200	51.2	35.8	10.8	3.6	0.962	1.5	2.6	37.1	30.6	7.8	1.9	0.882	1.1	1.9
	8	7	1200	60.5	40.3	12.7	5.3	1.312	1.8	3.1	44.7	33.9	9.5	3.5	1.228	1.4	2.3
16	4	7	1600	55.5	41.6	11.7	3.0	0.584	1.7	2.8	40.2	35.6	8.5	2.0	0.526	1.2	2.1
	6	7	1600	74.0	50.2	15.7	7.0	0.910	2.2	3.8	53.9	42.6	11.4	3.9	0.841	1.6	2.8
	8	7	1600	85.3	55.8	18.0	11.7	1.232	2.6	4.4	63.3	46.5	13.3	6.7	1.159	1.9	3.2
20	4	8	2000	67.2	50.7	14.2	3.5	0.668	1.8	3.0	44.9	44.9	9.5	2.1	0.497	1.2	2.0
	6	16	2000	76.7	56.4	16.1	1.6	0.998	1.0	1.7	55.7	48.9	11.8	0.9	0.909	0.7	1.2
	8	16	2000	93.9	64.0	19.9	2.8	1.374	1.2	2.1	68.4	54.3	14.4	1.5	1.275	0.9	1.5
30	4	10	3000	109.1	79.9	22.9	5.9	0.612	2.3	3.9	79.3	68.5	16.8	3.8	0.554	1.7	2.8
	6	15	3000	133.7	92.2	28.0	4.7	0.931	1.9	3.2	97.7	78.2	20.7	3.4	0.859	1.4	2.3
	8	15	3000	156.5	102.7	33.2	6.5	1.266	2.2	3.8	115.6	86.4	24.5	4.3	1.188	1.6	2.8
40	4	20	4000	130.4	100.2	27.7	2.5	0.613	1.4	2.3	88.7	88.7	19.1	1.8	0.462	1.0	1.6
	6	30	4000	161.5	116.6	34.2	1.5	0.938	1.1	1.9	116.5	100.0	24.6	1.4	0.855	0.8	1.4
	8	30	4000	194.1	130.6	40.9	2.4	1.284	1.4	2.3	141.7	109.8	29.8	2.2	1.196	1.0	1.7
50	4	20	5000	173.2	129.9	36.5	3.1	0.620	1.8	3.1	114.7	114.7	24.4	2.1	0.458	1.2	2.1
	6	30	5000	213.2	149.0	44.9	2.7	0.945	1.5	2.5	154.5	127.7	32.4	1.5	0.867	1.1	1.8
	8	30	5000	251.9	168.0	52.8	4.2	1.287	1.8	3.0	184.9	141.3	38.7	2.3	1.204	1.3	2.2
60	4	20	6000	216.5	159.7	45.5	5.1	0.625	2.3	3.9	157.5	136.9	33.4	2.9	0.565	1.7	2.8
	6	30	6000	265.7	182.6	55.7	3.5	0.949	1.9	3.1	194.2	156.5	41.2	2.5	0.877	1.4	2.3
	8	30	6000	309.8	203.5	64.8	5.5	1.290	2.2	3.7	230.0	171.1	48.7	3.9	1.212	1.6	2.8
80	4	26	8000	291.0	213.0	61.1	5.2	0.624	2.4	4.0	211.3	182.6	44.8	3.5	0.564	1.7	2.9
	6	39	8000	356.1	245.9	74.7	4.2	0.947	1.9	3.2	260.8	208.6	55.3	2.4	0.875	1.4	2.4
	8	52	8000	398.8	266.2	83.8	3.7	1.274	1.6	2.7	292.5	221.7	61.3	2.0	1.190	1.2	2.0
100	4	26	10000	382.7	272.6	81.3	10.2	0.625	3.1	5.3	276.5	233.6	58.4	5.5	0.566	2.2	3.8
	6	52	10000	441.9	304.3	92.6	3.3	0.933	1.8	3.0	322.8	260.8	68.5	2.4	0.861	1.3	2.2
	8	52	10000	518.7	342.3	110.3	5.6	1.271	2.1	3.6	382.5	285.2	81.0	3.8	1.190	1.6	2.6
120	4	52	12000	391.3	300.5	83.0	2.9	0.677	1.6	2.7	265.9	265.9	57.3	1.4	0.508	1.1	1.9
	6	52	12000	528.7	365.1	110.8	4.9	1.058	2.1	3.6	387.4	313.0	82.1	3.5	0.976	1.6	2.7
	8	52	12000	617.1	407.0	129.1	7.9	1.436	2.5	4.2	459.1	342.3	97.0	4.6	1.348	1.9	3.2

SYMBOLS: GPM: Gallons of water per minute
 WPD: Water pressure drop in feet of water
 APD: Air Pressure Drop

COOLING CAPACITIES - DX - ALL HORIZONTAL & VERTICAL UNITS

DX COOLING CAPACITIES - ENTERING AIR 80°F DB/67°F WB													
SIZE	ROWS	CIR.	CFM	SUCTION TEMPERATURE 42°F					SUCTION TEMPERATURE 45°F				
				TOTAL BTU	SENS BTU	LDB	LWB	APD	TOTAL BTU	SENS BTU	LDB	LWB	APD
08	4	3	800	32.8	22.7	54.1	53.8	0.641	28.2	20.9	56.1	55.9	0.641
	6	7	800	36.4	24.9	51.5	51.5	0.962	30.7	23.0	53.8	53.8	0.937
	8	7	800	44.1	28.9	47.0	47.0	1.282	38.1	26.1	50.2	50.2	1.274
12	4	7	1200	42.2	30.6	56.7	55.9	0.692	35.1	28.2	58.5	58.0	0.674
	6	7	1200	59.0	39.1	50.2	50.2	1.037	50.7	36.0	52.6	52.6	1.037
	8	7	1200	69.5	44.2	46.3	46.3	1.383	60.6	40.7	49.0	49.0	1.383
16	4	7	1600	63.6	44.2	54.7	54.3	0.641	54.3	40.7	56.7	56.4	0.641
	6	7	1600	84.1	55.5	48.3	48.3	0.962	73.3	50.1	51.4	51.4	0.962
	8	7	1600	96.2	61.2	45.0	45.0	1.282	85.2	56.4	47.8	47.8	1.282
20	4	8	2000	76.9	53.8	55.4	54.8	0.737	65.3	49.6	57.3	56.8	0.737
	6	16	2000	88.4	62.3	51.5	51.5	1.105	74.2	54.8	54.9	54.9	1.074
	8	16	2000	108.7	70.8	47.6	47.6	1.474	92.8	65.2	50.2	50.2	1.463
30	4	10	3000	124.6	85.0	54.1	53.6	0.662	107.7	78.3	56.1	55.7	0.662
	6	15	3000	154.0	102.0	48.9	48.9	0.993	133.4	93.9	51.4	51.4	0.993
	8	15	3000	178.3	114.7	45.0	45.0	1.324	157.4	103.7	48.4	48.4	1.324
40	4	20	4000	224.1	144.5	47.0	47.0	1.368	195.0	130.5	50.2	50.2	1.368
	6	30	4000	186.0	127.5	50.9	50.9	1.026	157.7	114.8	53.8	53.8	1.012
	8	30	4000	224.1	144.5	47.0	47.0	1.368	195.0	130.5	50.2	50.2	1.368
50	4	20	5000	199.2	138.1	54.7	54.2	0.680	170.2	127.2	56.7	56.3	0.680
	6	30	5000	246.9	162.9	50.2	50.2	1.019	211.1	150.0	52.6	52.6	1.019
	8	30	5000	291.9	187.7	45.7	45.7	1.359	254.5	169.6	49.0	49.0	1.359
60	4	20	6000	248.7	170.0	54.1	53.6	0.677	214.3	156.6	56.1	55.7	0.677
	6	30	6000	306.9	204.0	48.9	48.9	1.015	265.2	187.9	51.4	51.4	1.015
	8	30	6000	357.6	229.5	45.0	45.0	1.353	311.0	207.4	48.4	48.4	1.353
80	4	26	8000	333.7	226.6	54.1	53.6	0.674	287.4	208.7	56.1	55.7	0.677
	6	39	8000	409.7	272.0	48.9	48.9	1.011	356.0	250.5	51.4	51.4	1.011
	8	52	8000	460.1	294.6	46.3	46.3	1.348	401.5	271.4	49.0	49.0	1.348
100	4	26	10000	431.4	290.4	53.4	53.0	0.665	375.0	267.5	55.5	55.1	0.665
	6	52	10000	510.3	340.0	48.9	48.9	0.998	440.5	313.1	51.4	51.4	0.998
	8	52	10000	594.5	382.4	45.0	45.0	1.331	519.6	345.7	48.4	48.4	1.331
120	4	52	12000	447.8	314.5	56.0	55.2	0.752	378.6	289.6	57.9	57.2	0.752
	6	52	12000	605.8	399.4	49.6	49.6	1.129	525.7	367.9	52.0	52.0	1.129
	8	52	12000	702.7	450.4	45.7	45.7	1.505	620.6	414.9	48.4	48.4	1.505

SYMBOLS: LDB: Leaving dry bulb
 LWB: Leaving wet bulb
 APD: Air Pressure Drop

HEATING CAPACITIES FOR HORIZONTAL & VERTICAL UNITS 2 THRU 30 TONS

HOT WATER

ENTERING CONDITIONS: 70°F DB AIR/180°F EWT									
MODEL BWHB	ROWS	CIR.	CFM	TEMPERATURE DROP 20°F					
				TOTAL BTU	GPM	WPD	APD	GPM/CIR.	TUBE VEL.
08	1	2	800	31.1	3.3	1.4	0.106	1.6	2.8
	2	3	800	54.2	5.7	2.1	0.212	1.9	3.2
12	1	2	1200	47.6	5.0	3.5	0.114	2.5	4.3
	2	3	1200	82.2	8.7	5.3	0.229	2.9	4.9
16	1	3	1600	64.4	6.8	2.1	0.106	2.3	3.9
	2	3	1600	112.9	11.5	9.6	0.212	3.8	6.5
20	1	4	2000	76.0	8.0	1.8	0.122	2.0	3.4
	2	4	2000	136.6	14.5	8.1	0.244	3.6	6.1
30	1	5	3000	120.7	12.8	2.9	0.110	2.6	4.3
	2	10	3000	203.8	21.7	3.2	0.219	2.2	3.7
40	1	10	4000	152.0	16.1	1.4	0.113	1.6	2.7
	2	10	4000	274.8	29.2	4.8	0.226	2.9	4.9
50	1	10	5000	195.5	20.6	2.5	0.112	2.1	3.5
	2	10	5000	348.5	37.0	7.1	0.225	3.7	6.3
60	1	10	6000	239.6	25.4	2.9	0.112	2.5	4.3
	2	10	6000	420.2	42.9	10.4	0.224	4.3	7.3
80	1	13	8000	320.6	34.0	2.7	0.111	2.6	4.4
	2	19	8000	553.5	58.8	3.6	0.223	3.1	5.2
100	1	13	10000	409.6	43.4	4.8	0.110	3.3	5.7
	2	19	10000	702.4	74.5	6.3	0.220	3.9	6.6
120	1	13	12000	476.7	100.9	6.7	0.124	7.8	13.1
	2	26	12000	811.3	86.3	5.5	0.249	3.3	5.6

STEAM

HEATING CAPACITIES - STEAM: 5 PSI						
MODEL BWHB	ROWS	CFM	ENTERING AIR 70°F			
			TOTAL BTU	LDB	#S COND	APD
08	1	800	58.2	136.5	60.6	0.144
	2	800	88.5	171.1	92.1	0.287
12	1	1200	85.4	135.1	88.9	0.156
	2	1200	130.7	169.6	136.0	0.312
16	1	1600	116.4	136.5	121.2	0.144
	2	1600	176.9	171.1	184.2	0.287
20	1	2000	139.7	133.9	145.5	0.167
	2	2000	215.0	168.3	223.8	0.335
30	1	3000	216.2	135.9	225.1	0.149
	2	3000	329.6	170.5	343.1	0.298
40	1	4000	285.6	135.3	297.3	0.154
	2	4000	436.5	169.8	454.5	0.308
50	1	5000	357.7	135.4	372.4	0.153
	2	5000	546.4	169.9	568.8	0.306
60	1	6000	429.7	135.5	447.4	0.152
	2	6000	656.3	170.0	683.2	0.305
80	1	8000	573.6	135.6	597.2	0.152
	2	8000	875.7	170.1	911.7	0.303
100	1	10000	719.7	135.8	749.2	0.150
	2	10000	1097.5	170.4	1142.5	0.299
120	1	12000	833.3	133.5	867.6	0.171
	2	12000	1284.1	167.9	1336.8	0.343

SYMBOLS: LDB: Leaving dry bulb
 GPM: Gallons of water per minute
 WPD: Water pressure drop in feet of water
 APD: Air Pressure Drop

SOUND POWER LEVELS - OCTAVE BAND SOUND POWER LEVEL, dB RE: 10 ¹² WATTS										
MODEL	POINT OF OPERATION	LOCATION	63	125	250	500	1000	2000	4000	8000
08	600 CFM AT 0.79" 1100 RPM	INLET	60	61	59	55	49	45	37	26
		OUTLET	71	76	69	67	67	65	61	55
	800 CFM AT 0.53" 1100 RPM	INLET	60	64	59	55	50	46	38	27
		OUTLET	71	77	69	68	68	65	62	57
	900 CFM AT 0.35" 1100 RPM	INLET	60	65	59	55	51.5	47	40	31
OUTLET		69	77	70	68	68	66	63	58	
12	900 CFM AT 0.87" 1216 RPM	INLET	73	70	64	58	52	48	41	28
		OUTLET	79	81	75.5	72	72	69	66	62
	1200 CFM AT 0.52" 1216 RPM	INLET	73	69	64	59	53.5	49	41	30
		OUTLET	79	82	75.5	72	72.5	70	67	62
	1500 CFM AT 0.28" 1216 RPM	INLET	72	66	63	59	54	50	43	32
OUTLET		75	76	76	72	73	70	68	58	
16	1201 CFM AT 0.68" 1134 RPM	INLET	75	70	66	64	55	50	42	32
		OUTLET	77	80	75	71.5	72	69	66	60
	1604 CFM AT 0.52" 1126 RPM	INLET	75	70	66	64	58	53	44	35
		OUTLET	78	80	76	72.5	74	71	69	64
	1972 CFM AT 0.20" 1117 RPM	INLET	74	71	66	66	57	54	46	38
OUTLET		76	79	76	74	76	73	72	67	
20	1600 CFM AT 0.75" 1035 RPM	INLET	68	75	67	62	56	52	47	33.5
		OUTLET	76	82	78	75	73.5	71	69	63
	2000 CFM AT 0.62" 1027 RPM	INLET	68	77	68	63	57	55	48	34.5
		OUTLET	77	83	78	76	74	72	70	64
	2400 CFM AT 0.30" 1016 RPM	INLET	68	76	67	65	59	54	49	37
OUTLET		78	84	79	77	76	73	71.5	66	
30	2250 CFM AT 0.28" 631 RPM	INLET	65	66	61	57	55	47	38.5	35
		OUTLET	79	72	70	69	66.5	65	61	53
	3000 CFM AT 0.51" 820 RPM	INLET	73	73	64	64	63	54	46.5	36
		OUTLET	82	79	77	76	73	71	69	62
	3750 CFM AT 0.80" 1200 RPM	INLET	76	77	67	71	64	59	51.5	41
OUTLET		84	83	81	80	80	76	75	69	
40	3000 CFM AT 0.66" 790 RPM	INLET	70.5	69	66	61	61	51.5	44	34.5
		OUTLET	79	77	76	74	74	69	67	59
	4000 CFM AT 0.70" 1052 RPM	INLET	76	76	68	67	67	58	52	41
		OUTLET	85	84	83	81.5	81.5	76.5	75	69
	4670 CFM AT 0.88" 1200 RPM	INLET	77	79	72	70	70	65	56	45.5
OUTLET		87	88	85.5	84	84	80	78	72.6	
50	3750 CFM AT 0.34" 783 RPM	INLET	72	70	64	66	66	53	43	37
		OUTLET	83	77	75	75	74	70	69	61
	5000 CFM AT 0.70" 1048 RPM	INLET	75	76	70	73.5	65	60	53.5	43.3
		OUTLET	83	83	82	80	80	77	76	70
	5357 CFM AT 0.70" 1084 RPM	INLET	76.5	76	71	73	67.5	61	55	45
		OUTLET	84	83.5	83	81	81	76	78	72
6250 CFM AT 0.90" 1237 RPM	INLET	79	79	74	70	77	65	58	49	
	OUTLET	87	86	86	84	85.5	82	81	76	
60	4500 CFM AT 0.39" 683 RPM	INLET	74	72	63	68	62	55	48	41
		OUTLET	81	79	75	76	74	71	70.5	61
	6000 CFM AT 0.70" 890 RPM	INLET	81	78	70	71	68	61	54	44
		OUTLET	88	85	82	82	81	78	76	70
	7500 CFM AT 1.07" 1106 RPM	INLET	83.5	82	73	75	81	67	60	50
OUTLET		92	90	87	87	89	84	82	77	
80	6000 CFM AT 0.38" 684 RPM	INLET	75	72	64	63	62	57	48.5	38
		OUTLET	84	79	77	77	74	72	70	63
	8000 CFM AT 0.70" 890 RPM	INLET	78	78	69.5	69	70	63.5	56	44
		OUTLET	87	86	83	82	83	79	77.5	71.5
	10000 CFM AT 1.02" 1092 RPM	INLET	81	81	74	73	74.5	69	61.5	50
OUTLET		90	89	88.5	87	87.5	84.5	83	78	
100	8000 CFM AT 0.40" 688 RPM	INLET	76	72	65	64	62	56	48	40
		OUTLET	84	79	77	77	73	71	71	63
	10000 CFM AT 0.7" 890 RPM	INLET	79	78	70	69	71	64	56	44.5
		OUTLET	88	86	83	82	84	80	78	72
	11500 CFM AT 1.05" 1100 RPM	INLET	82	83	74	74	76	70	62	50
OUTLET		92	90	89	88	88	84	83	78	
120	10000 CFM AT 0.45" 700 RPM	INLET	75.5	73	66	64	62	57	49	41
		OUTLET	85	80	78.5	77	74	73	72	64

MOTOR SPECIFICATION GUIDE

Motors may be custom selected to meet job requirements.

- Factory installed motors on heavy-duty steel mounts
- Mounts designed to maintain precise alignment and simplify belt adjustment
- Set midpoint to meet the specified CFM and total static pressure
- Motor full load amps listed refer to NEC amps. Actual motor nameplate amps may vary.
- Belt Drive motors are open drip-proof, ball-bearing,

single speed, rated at continuous duty, ambient, with reversible rotation.

- Standard single-phase motors are resilient base, capacitor start and include built-in thermal overload protection.
- Standard three-phase motors are rigid base and have no overload protection.
- High efficiency motors E-plus meet the requirements of the latest Epact standards, also E-plus 3 motors exceed the requirements of the Epact are available.

ALL CHARTS SHOW FULL LOAD AMPS

HORSEPOWER	60 HERTZ THREE-PHASE MOTORS (1800RPM)				60 HERTZ SINGLE-PHASE MOTORS (1800RPM)			
	115V	208V	230V	460V	208V	230V	460V	575V
1/3	6.6	3.6	3.3	-	1.8	1.6	0.8	-
1/2	9.0	4.9	4.5	-	3.3	3.0	1.5	0.9
3/4	11.0	6.0	5.5	-	3.8	3.4	1.7	1.0
1	12.6	6.9	6.3	-	3.0	2.7	1.4	1.4
1 1/2	15.0	8.2	7.5	-	4.3	3.9	2.0	2.0
2	20.4	11.2	10.2	-	5.7	5.2	2.6	2.4
3	31.0	-	15.5	-	9.5	8.6	4.3	3.6
5	25.0	-	12.5	-	14.1	12.8	6.4	5.1
7 1/2	-	-	32.0	16.0	21.2	19.2	9.6	7.8
10	-	-	38.0	19.0	29.6	26.8	13.4	10.3

HORSEPOWER	60 HERTZ TWO-SPEED THREE-PHASE MOTORS (1800/900 RPM) ONE WINDING			60 HERTZ TWO-SPEED THREE-PHASE MOTORS (1800/1200 RPM) TWO WINDING		
	115V	208V	230V	208V	230V	460V
1/2	-	-	-	1.8/1.1	1.9/1.2	0.95/0.6
3/4	-	-	-	2.5/1.5	2.7/1.6	1.35/0.82
1	3.5/1.5	3.4/1.6	1.8/0.75	3.2/1.8	3.4/2.2	1.7/1.1
1 1/2	5.0/2.1	4.8/2.7	2.25/0.95	5.0/2.9	4.9/2.8	2.4/1.4
2	6.2/2.6	6.4/2.7	3.0/1.3	6.1/3.5	5.9/3.8	3.0/2.0
3	9.1/3.3	8.3/3.3	4.5/1.8	9.0/4.8	8.4/4.8	4.6/2.6
5	14.7/5.2	13.4/5.1	7.0/2.7	16.9/9.7	15.5/10.2	7.1/4.8
7 1/2	24.5/10.0	24.5/11.0	10.5/4.2	22.0/12.3	19.5/12.3	10.0/6.0
10	29.5/11.3	30.0/12.4	13.0/5.5	30.0/17.5	28.0/17.5	13.5/7.5

HORSEPOWER	60 HERTZ THREE-PHASE MOTORS (1725 RPM)	50 HERTZ THREE-PHASE MOTORS (1500 RPM)	
	277V	190V	380V
1/3	2.2	1.6	0.8
1/2	3.0	2.2	1.1
3/4	4.3	2.6	1.3
1	5.4	3.8	1.9
1 1/2	6.2	5.4	2.7
2	-	7.2	3.6
3	-	9.6	4.8
5	-	15.6	7.8
7 1/2	-	23	11.5
10	-	30	15.0

60 HERTZ TWO-SPEED SINGLE-PHASE MOTORS (1800/1200 RPM) TWO WINDING			
HORSEPOWER	208V	230V	460V
1/3	5.0/3.0	-	-
1/2	6.8/3.8	-	-
3/4	10.0/4.0	5.0/2.5	4.6/2.3
1	11.9/6.9	6.3/3.0	6.0-3.6

BASIC/DELUXE HORIZONTAL 800 THRU 2000 CFM (2 THRU 5 TONS)

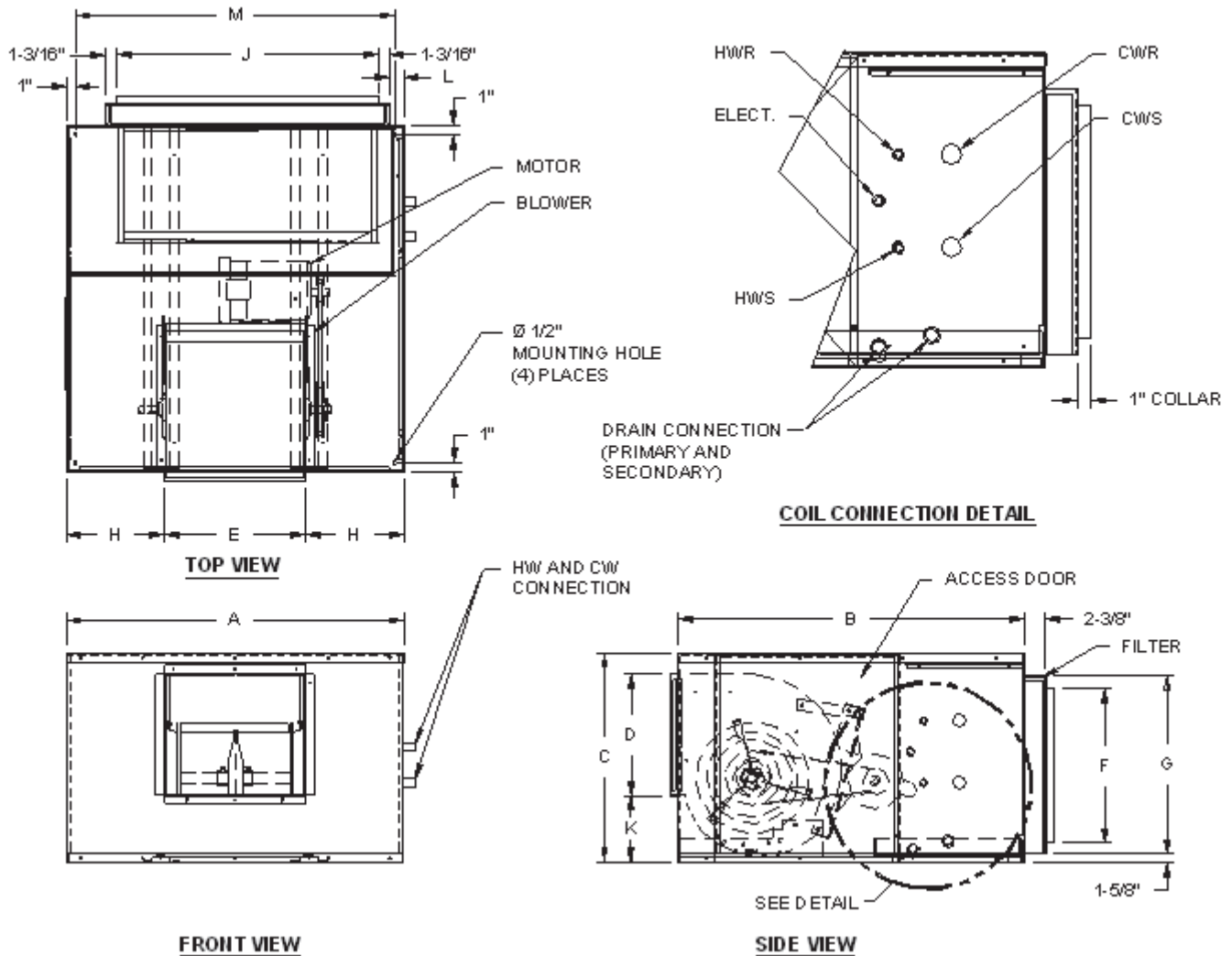

DIMENSIONS - HORIZONTAL AIR HANDLER 800 THRU 2000 CFM														
MODEL	A	B	C	D	E	F	G	H	J	K	L	M	N	FILTER SIZE
08	24 1/8	39 1/8	20 1/2	11 11/16	8 9/16	17 1/2	20	7 3/4	18	6 5/8	1	22 1/8	26	(1) 20x20x2
12	30 1/8	39 1/8	20 1/2	11 11/16	13 1/2	17 1/2	20	8 5/16	23	6 5/8	1	28 1/8	32	(1) 20x25x2
16	38 1/16	39 1/8	20 1/2	11 11/16	13 1/2	17 1/2	20	12 1/4	29 5/8	6 5/8	1 3/8	36 1/16	40	(2) 16x20x2
20	38 1/16	39 1/8	23 11/16	13 13/16	15 15/16	17 1/2	20	11 1/16	29 5/8	7 9/16	1 3/8	36 1/16	40	(2) 16x20x2

Model BWHB & BXHB-08 thru 20 / BWHD & BXHD-08 thru 20 (B=Basic, D=Deluxe)

- Right-hand unit shown, left-hand unit opposite.
- Coil connections determined by facing the supply-air opening.
- Electrical junction box is located on the same side as the coil connections.
- Drain pan is powder-coated epoxy with a 1/4" thick closed-cell insulation and has 3/4" to 1" NPT primary and secondary drain connections.

BASIC/DELUXE HORIZONTAL 3000 CFM (7.5 TONS)

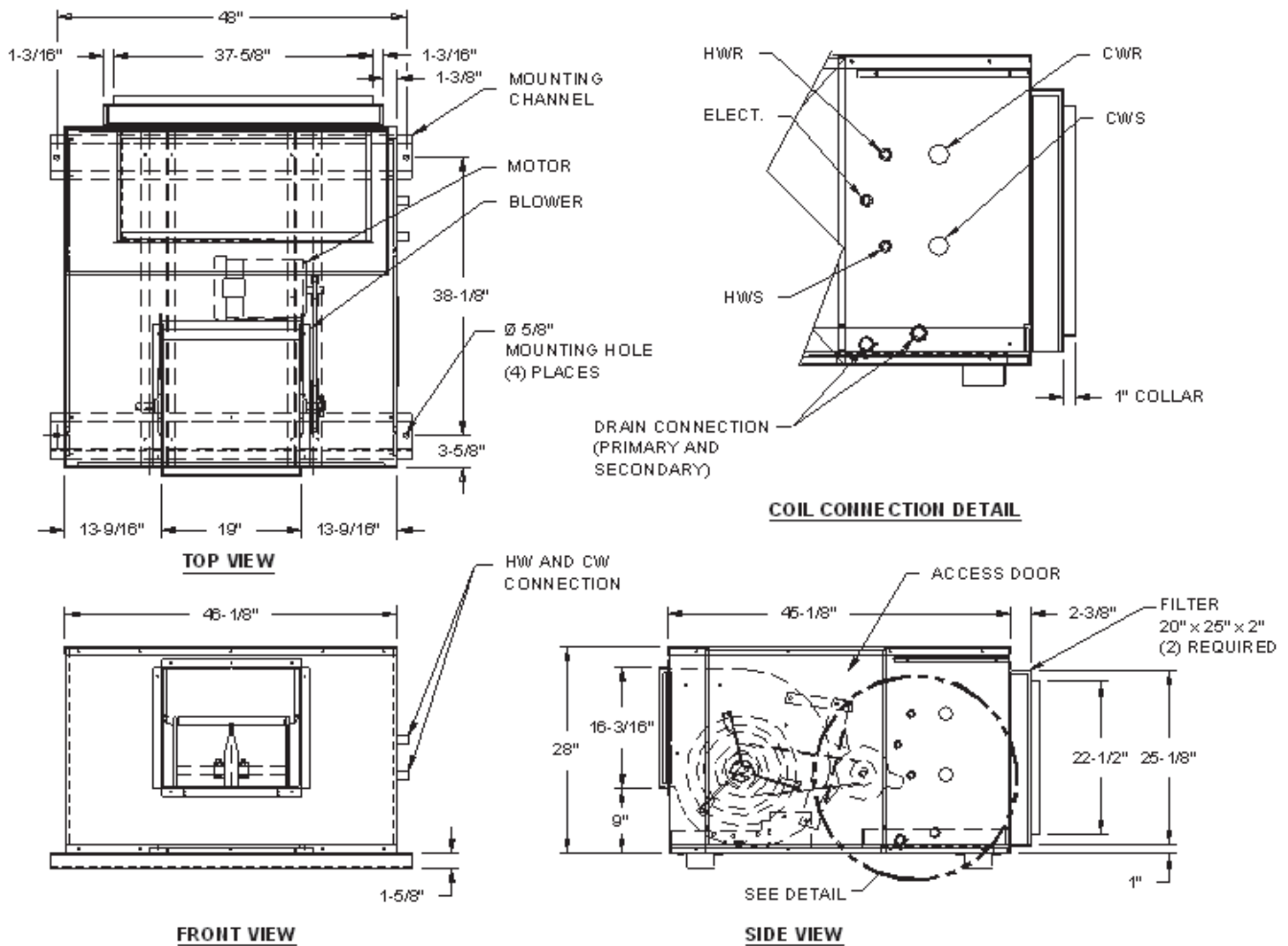

Model BWHB & BXHB-30 / BWHD & BXHD-30 (B=Basic, D=Deluxe)

- Right-hand unit shown, left-hand unit opposite.
- Coil connections determined by facing the supply-air opening.
- Electrical junction box is located on the same side as the coil connections.
- Drain pan is powder-coated epoxy with a 1/4" thick closed-cell insulation and has 3/4" to 1" NPT primary and secondary drain connections.

BASIC/DELUXE HORIZONTAL 4000 THRU 12,000 CFM (10 THRU 30 TONS)

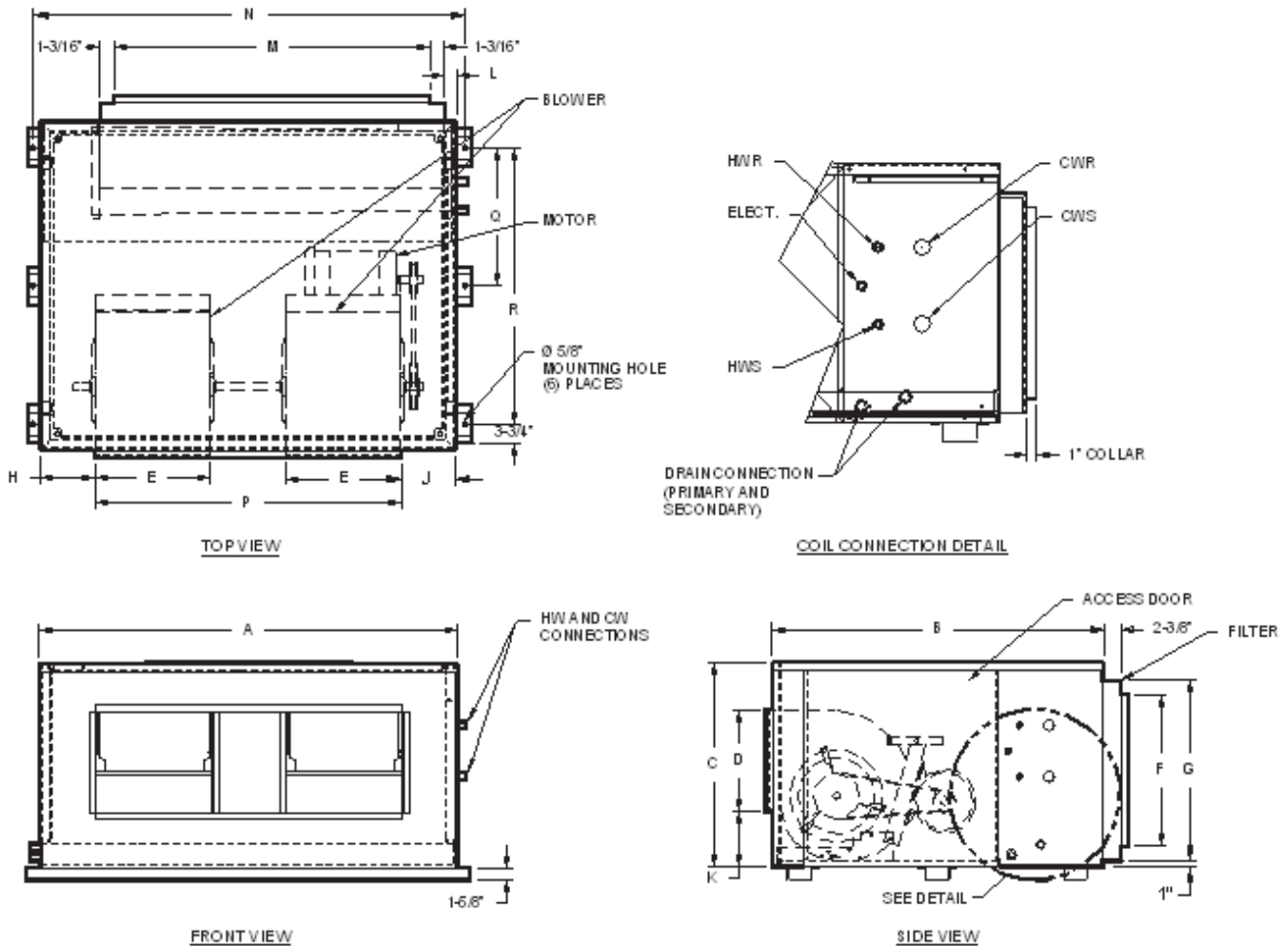

DIMENSIONS - HORIZONTAL AIR HANDLER 4000 THRU 12,000 CFM																	
MODEL	A	B	C	D	E	F	G	H	J	K	L	M	N	P	Q	R	FILTER SIZE
40	57 1/8	45 3/16	27 15/16	13 13/16	15 15/16	22 9/16	25 1/8	6 1/8	6 1/8	7 1/2	1 7/16	48 3/16	59	44 13/16	N/A	37 11/16	(2) 25x25x2
50	71 1/8	45 3/16	27 15/16	13 13/16	15 15/16	22 9/16	25 1/8	16 1/8	10 1/8	7 1/2	1 7/16	62 3/16	73	44 13/16	N/A	37 11/16	(4) 16x25x2
60	85 1/8	45 3/16	27 15/16	16 3/16	18 15/16	22 9/16	25 1/8	18 1/8	12 1/8	9	1 3/8	72 11/16	87	54 13/16	18 3/16	37 11/16	(3) 25x25x2
80	85 1/8	45 3/16	35 3/16	16 3/16	18 15/16	29 13/16	32 3/16	18 1/8	12 1/8	9	7/16	76 11/16	87	54 13/16	18 3/16	37 11/16	(8) 16x20x2
100	105 3/8	45 3/16	35 3/16	16 3/16	18 7/8	30 9/16	32 5/16	30 1/4	20 3/8	9	7/16	103 1/16	107	54 3/4	18 7/8	37 11/16	(8) 16x20x2 (2) 16x25x2
120	116 5/16	55 1/4	35 3/16	16 3/16	18 7/8	30 9/16	32 5/16	30 13/16	30 3/4	9	7/16	104 1/2	118 1/2	54 3/4	23 7/8	47 3/4	(8) 16x25x2 (2) 16x25x2

Model BWHB & BXHB-40 thru 120 / BWHD & BXHD-40 thru 120 (B=Basic, D=Deluxe)

- Right-hand unit shown, left-hand unit opposite.
- Coil connections determined by facing the supply-air opening.
- Electrical junction box is located on the same side as the coil connections.
- Drain pan is powder-coated epoxy with a 1/4" thick closed-cell insulation and has 1" to 1 1/2" NPT primary and secondary drain connections.

Angular Filter Section

Dimensional Drawings

HORIZONTAL UNIT WITH ANGULAR FILTER SECTION OPTION - 800 THRU 2,000 CFM (2 THRU 5 TONS)

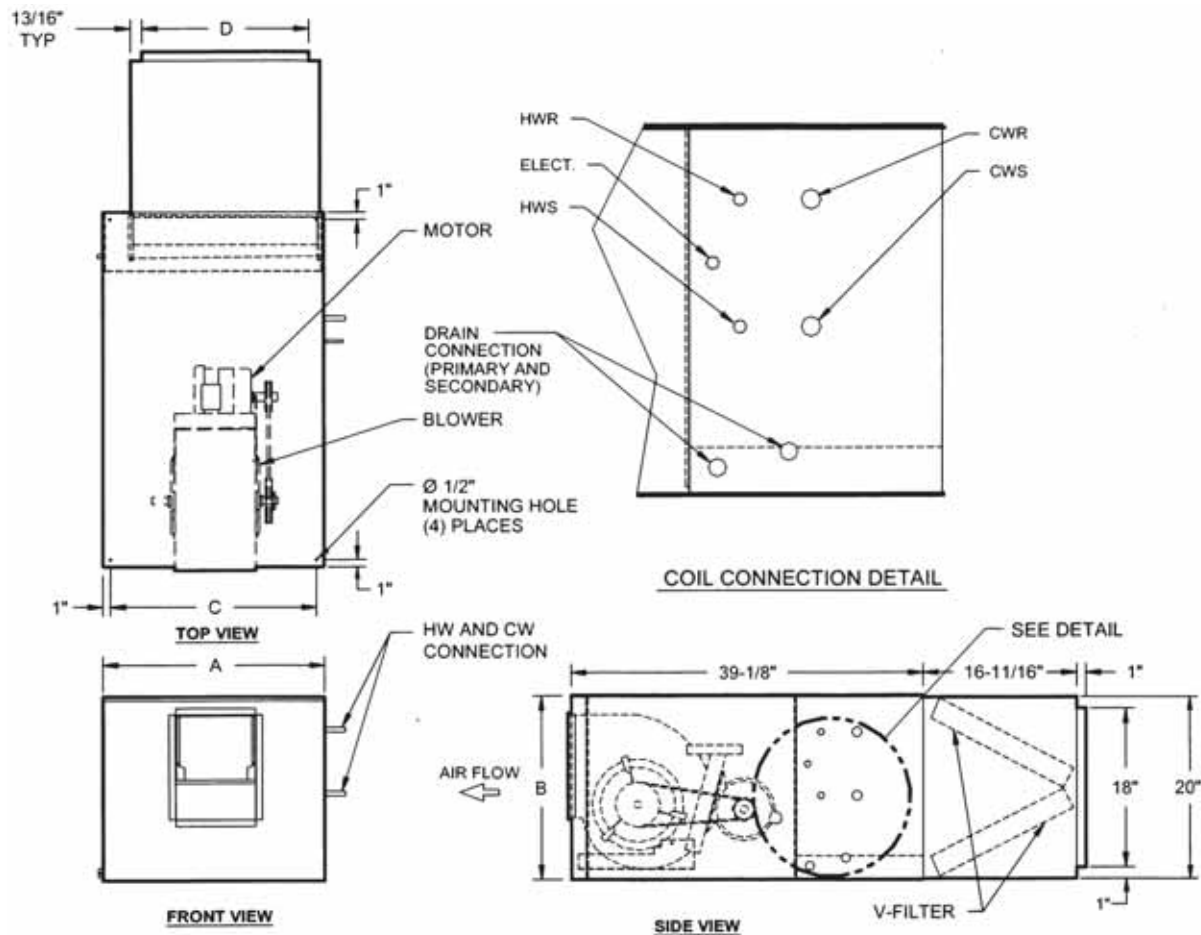

HORIZONTAL WITH ANGULAR FILTER - 800 THRU 2000 CFM					
MODEL BBHW	A	B	C	D	FILTER SIZE
08	24 1/8	20 1/2	22 1/8	17 7/8	(2) 16X20X2
12	30 1/16	20 1/2	28 1/16	22 7/8	(2) 16X25X2
16	38 1/16	20 1/2	36 1/16	29 7/8	(2) 16X25X2
20	38 1/16	23 11/16	36 1/16	30 1/8	(4) 16X20X2

Model BWHB & BXHB-08 thru 20 / BWHD & BXHD-08 thru 20 (B=Basic, D=Deluxe)

- Right-hand unit shown, left-hand unit opposite.
- Coil connections determined by facing the supply-air opening.
- Electrical junction box is located on the same side as the coil connections.
- Drain pan is powder-coated epoxy with a 1/4" thick closed-cell insulation and has 3/4" to 1" NPT primary and secondary drain connections.

HORIZONTAL UNIT WITH ANGULAR FILTER SECTION OPTION - 3,000 CFM (7.5 TONS)

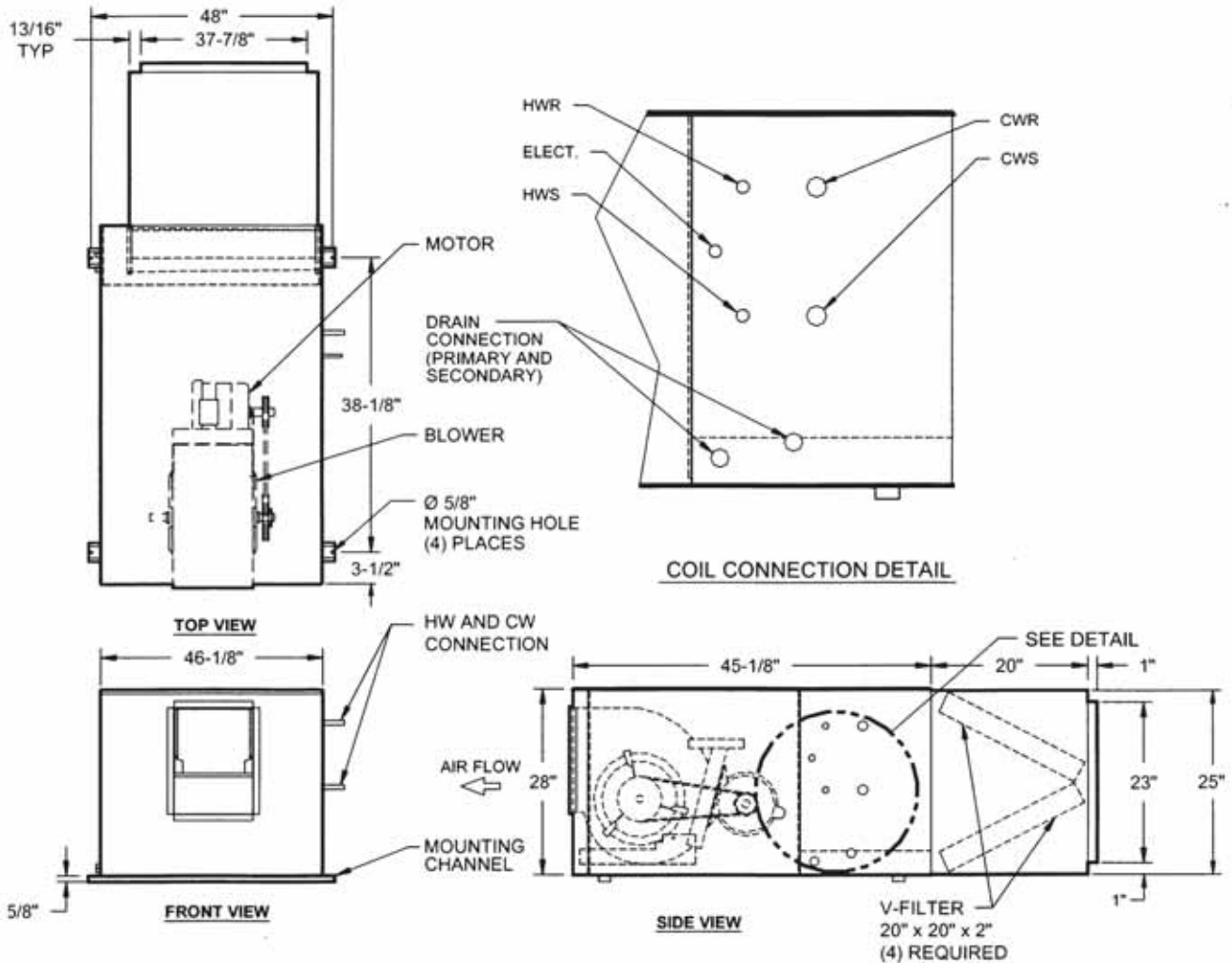

Model BWHB & BXHB-30 / BWHD & BXHD-30 (B=Basic, D=Deluxe)

- Right-hand unit shown, left-hand unit opposite.
- Coil connections determined by facing the supply-air opening.
- Electrical junction box is located on the same side as the coil connections.
- Drain pan is powder-coated epoxy with a 1/4" thick closed-cell insulation and has 3/4" to 1" NPT primary and secondary drain connections.

HORIZONTAL UNIT WITH ANGULAR FILTER SECTION OPTION - 4,000 THRU 12,000 CFM (10 THRU 30 TONS)

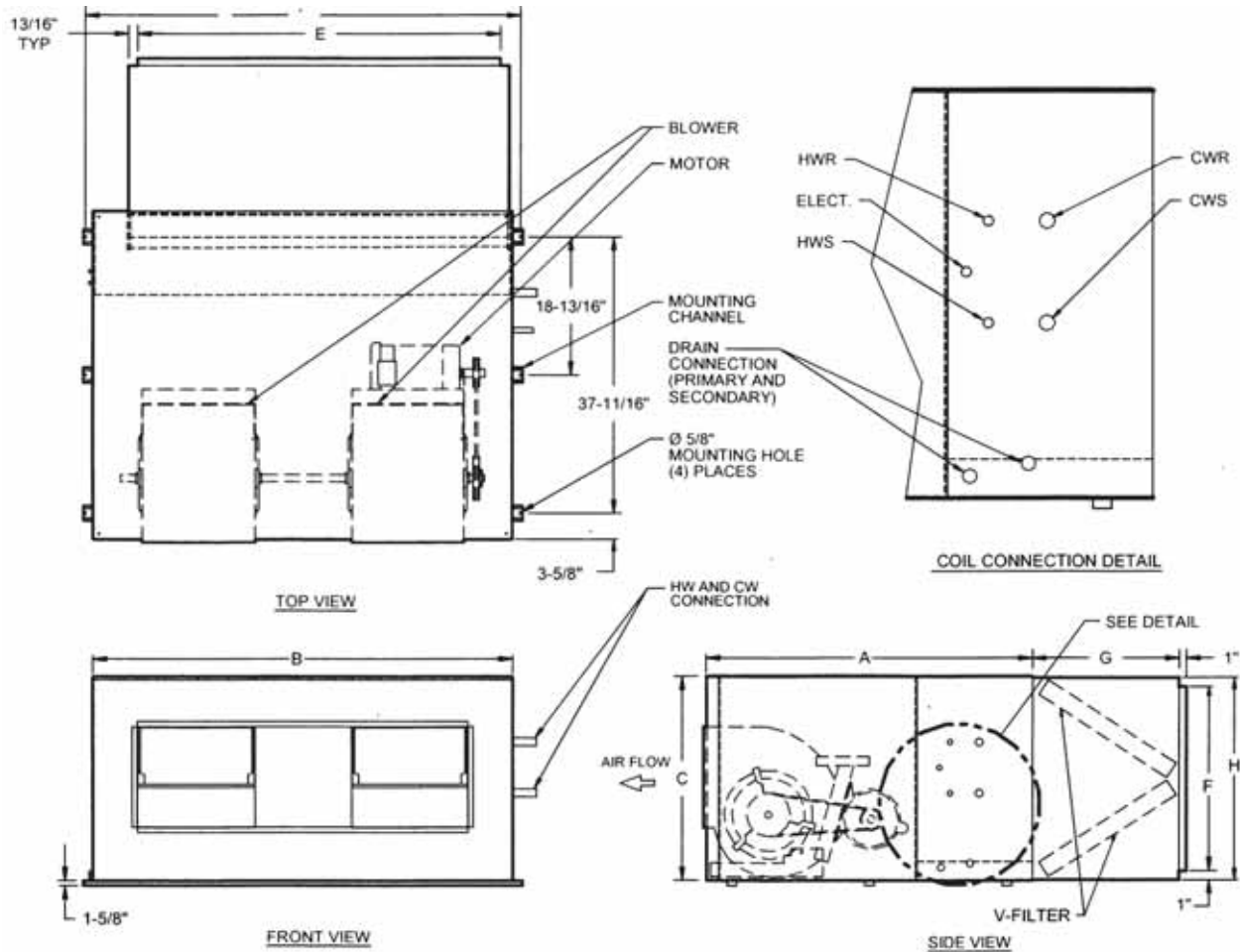

HORIZONTAL WITH ANGULAR FILTER 4,000 THRU 12,000 CFM									
MODEL	A	B	C	D	E	F	G	H	FILTER SECTION
40	45 3/16	57 1/8	27 15/16	59	47 7/8	23	20	25	(4) 20X25X2
50	45 3/16	71 1/8	27 15/16	73	62 7/8	23	20	25	(6) 20X20X2
60	45 3/16	85 1/8	27 15/16	87	77 7/8	23	20	25	(8) 20X20X2
80	45 3/16	85 1/8	35 3/16	87	77 7/8	30	23 11/16	32	(8) 20X25X2
100	45 3/16	105 3/8	35 3/16	107	97 7/8	30	23 11/16	32	(8) 20X25X2
120	55 1/4	116 5/16	35 3/16	118 1/2	104 3/8	30	23 11/16	32	(8) 20X25X2

Model BWHB & BXHB-40 thru 120 / BWHD & BXHD-40 thru 120 (B=Basic, D=Deluxe)

- Right-hand unit shown, left-hand unit opposite.
- Coil connections determined by facing the supply-air opening.
- Electrical junction box is located on the same side as the coil connections.
- Drain pan is powder-coated epoxy with a 1/4" thick closed-cell insulation and has 1" to 1 1/2" NPT primary and secondary drain connections.

BASIC/DELUXE VERTICAL 800 THRU 3000 CFM (2 THRU 7.5 TONS)

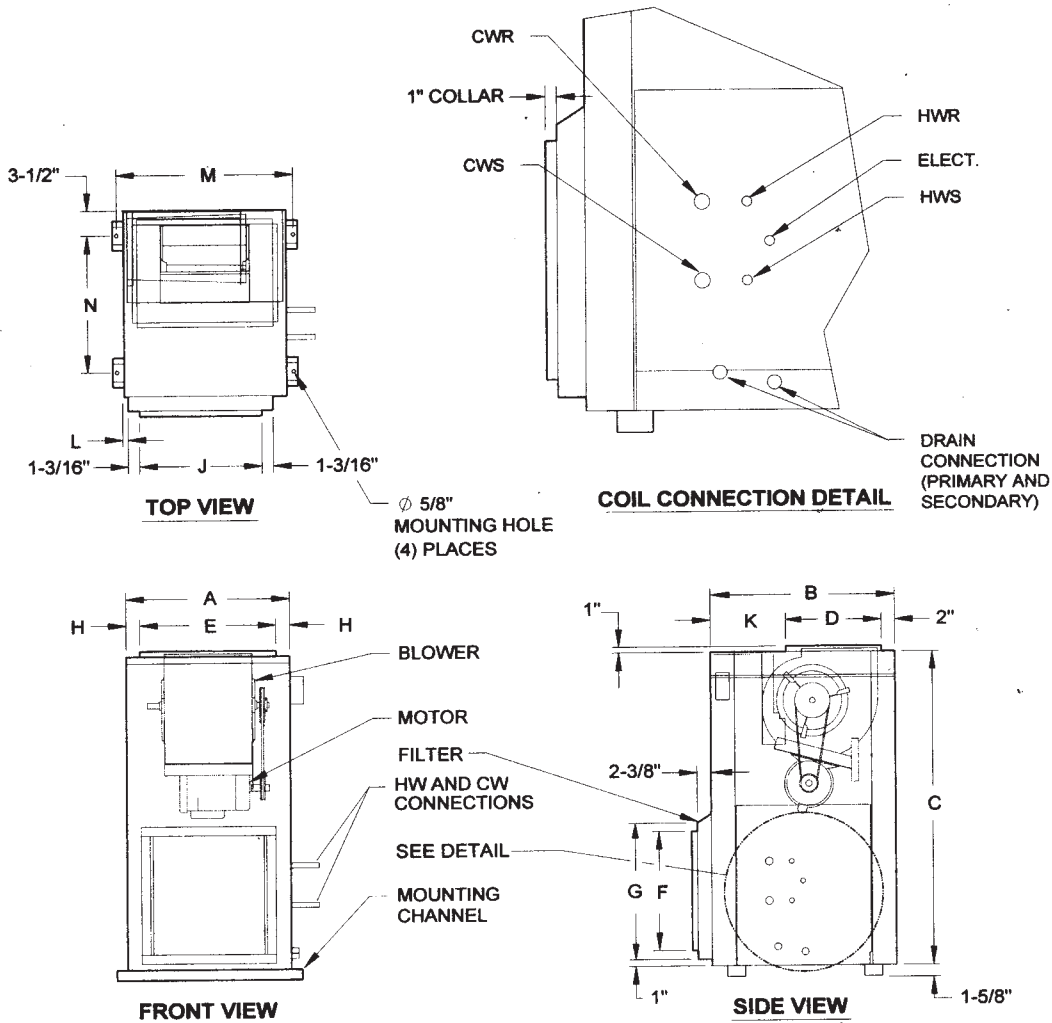

DIMENSIONS - VERTICAL AIR HANDLER 800 THRU 3000 CFM														
MODEL	A	B	C	D	E	F	G	H	J	K	L	M	N	FILTER SIZE
08	24 1/16	27 1/8	46	14	20	17 1/2	20	2 1/32	18	11 1/8	1	26	20 1/8	(1) 20x20x2
12	30 1/16	27 1/8	46	14	20	17 1/2	20	5 1/32	23	11 1/8	1	32	20 1/8	(1) 20x25x2
16	38 1/16	27 1/8	46	16	22	17 1/2	20	8 1/32	29 5/8	9 1/8	1 3/8	40	20 1/8	(2) 16x20x2
20	38 1/16	27 1/8	54	18	24	17 1/2	20	7 1/16	29 5/8	7 1/8	1 3/8	40	20 1/8	(2) 16x20x2
30	46 1/8	27 1/8	60	20	30	22 1/2	25 1/8	8 1/8	37 5/8	5 1/4	1 3/8	48	20 1/4	(2) 20x25x2

Model BWVB & BXVB-08 thru 30 / BWVD & BXVD-08 thru 30 (B=Basic, D=Deluxe)

- Right-hand unit shown, left-hand unit opposite.
- Coil connections determined by facing the supply-air opening.
- Electrical junction box is located on the same side as the coil connections.
- Drain pan is powder-coated epoxy with a 1/4" thick closed-cell insulation and has 3/4" to 1" NPT primary and secondary drain connections.

BASIC/DELUXE VERTICAL 4000 THRU 12,000 CFM (10 THRU 30 TONS)

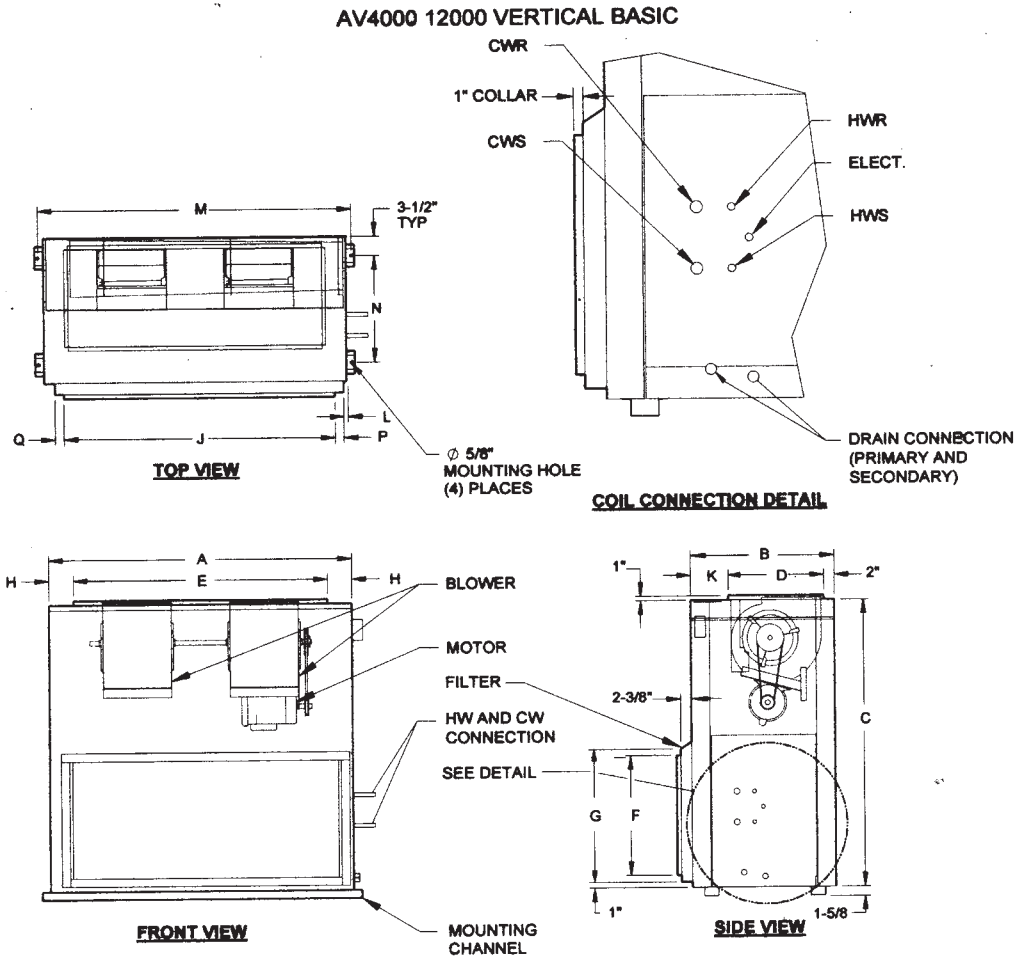

BASIC VERTICAL - 4000 THRU 12,000 CFM																
MODEL	A	B	C	D	E	F	G	H	J	K	L	M	N	P	Q	FILTER SIZE
40	57 1/4	27 1/4	54	18	48	22 9/16	25 1/8	4 5/8	48 1/8	7 1/4	1 3/8	59	19 5/8	1 3/8	1 3/16	(2) 25x25x2
50	71 1/4	27 1/4	54	20	54	22 9/16	25 1/8	8 5/8	62 1/8	5 1/4	2 1/2	73	19 5/8	1 1/2	1 3/16	(4) 16x25x2
60	85 1/4	27 1/4	60	20	60	22 9/16	25 1/8	12 11/16	72 5/8	5 1/4	1 3/8	87	19 5/8	1 1/2	1 3/16	(3) 25x25x2
80	85 1/4	27 1/4	67	24	72	30 1/8	32 1/8	6 5/8	76 1/2	1 1/4	0	87	19 5/8	1 1/2	1 7/8	(8) 16x20x2
100	105 1/4	27 1/4	67	24	90	30 1/8	32 1/8	7 5/8	102 7/8	1 1/4	0	107 1/4	19 5/8	1 1/2	1 7/8	(8) 16x20x2 (2) 16x25x2
120	116 1/4	34 1/4	83	28	90	30	40	13 1/8	104 3/8	4 1/4	0	118 1/4	26 5/8	1 1/2	1 7/8	(8) 20x25x2 (2) 16x25x2

Model BWVB & BXVB-40 thru 120 / BWVD & BXVD-40 thru 120 (B=Basic, D=Deluxe)

- Right-hand unit shown, left-hand unit opposite.
- Coil connections determined by facing the supply-air opening.
- Electrical junction box is located on the same side as the coil connections.
- Drain pan is powder-coated epoxy with a 1/4" thick closed-cell insulation and has 1" to 1 1/2" NPT primary and secondary drain connections.

VERTICAL UNIT WITH ANGULAR FILTER SECTION OPTION - 800 THRU 3,000 CFM (2 THRU 7.5 TONS)

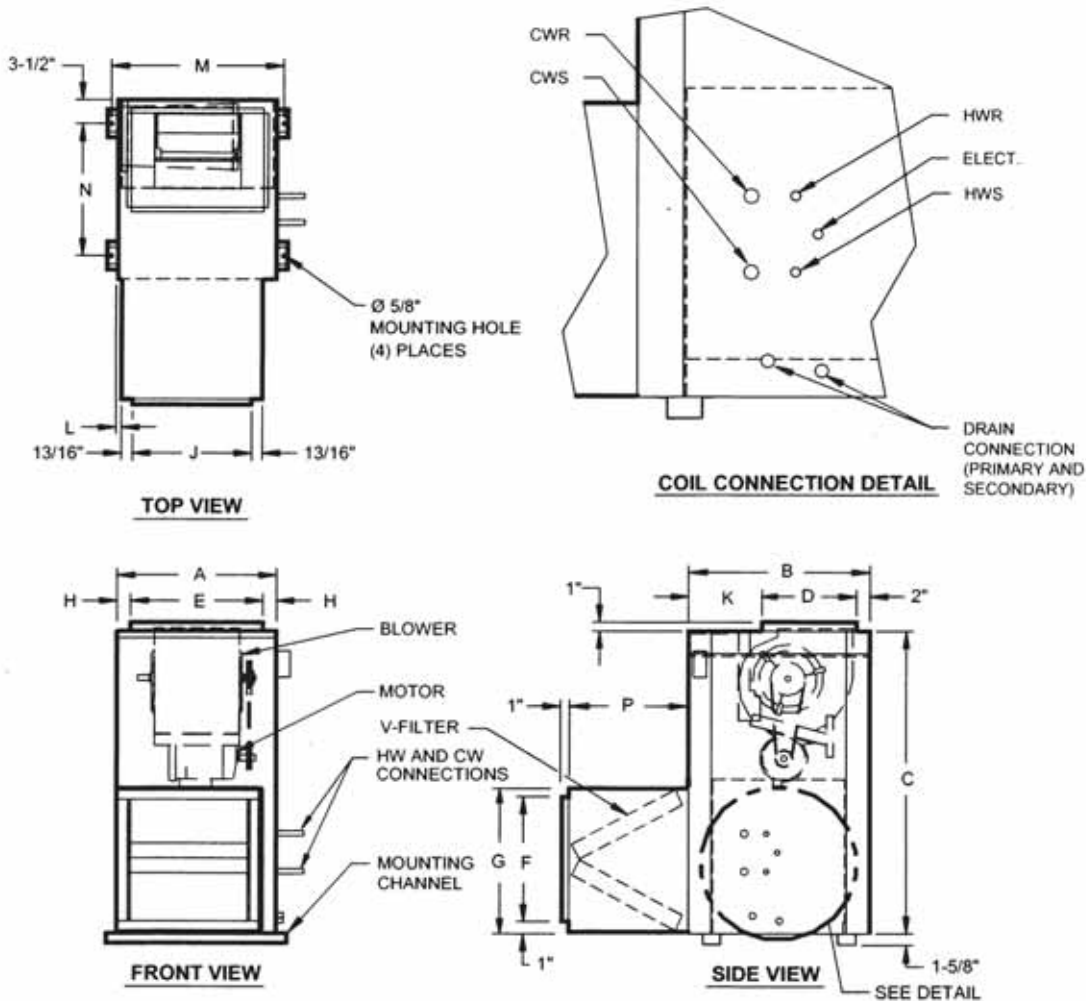

VERTICAL WITH ANGULAR FILTER 800 THRU 3,000 CFM															
MODEL	A	B	C	D	E	F	G	H	J	K	L	M	N	P	FILTER SIZE
08	24 1/16	27 1/8	46	14	20	18	20	2 1/32	17 7/8	11 1/8	1	26	20 1/8	16 11/16	(2) 16X20X2
12	30 1/16	27 1/8	46	14	20	18	20	5 1/32	22 7/8	11 1/8	1	32	20 1/8	16 1/16	(2) 16X25X2
16	38 1/16	27 1/8	46	16	22	18	20	8 1/32	29 7/8	9 1/8	1 3/8	40	20 1/8	16 1/16	(4) 16X16X2
20	38 1/16	27 1/8	54	18	24	18	20	7 1/16	30 1/8	7 1/8	1 3/8	40	20 1/8	16 1/16	(4) 16X16X2
30	46 1/8	27 1/4	60	20	30	23	25	8 1/8	37 7/8	5 1/4	1 3/8	48	20 1/4	20	(4) 20X20X2

Model BWVB & BXVB-08 thru 30 / BWVD & BXVD-08 thru 30 (B=Basic, D=Deluxe)

- Right-hand unit shown, left-hand unit opposite.
- Coil connections determined by facing the supply-air opening.
- Electrical junction box is located on the same side as the coil connections.
- Drain pan is powder-coated epoxy with a 1/4" thick closed-cell insulation and has 3/4" to 1" NPT primary and secondary drain connections.

Angular Filter Section

Dimensional Drawings

VERTICAL UNIT WITH ANGULAR FILTER SECTION OPTION - 4,000 THRU 12,000 CFM (10 THRU 30 TONS)

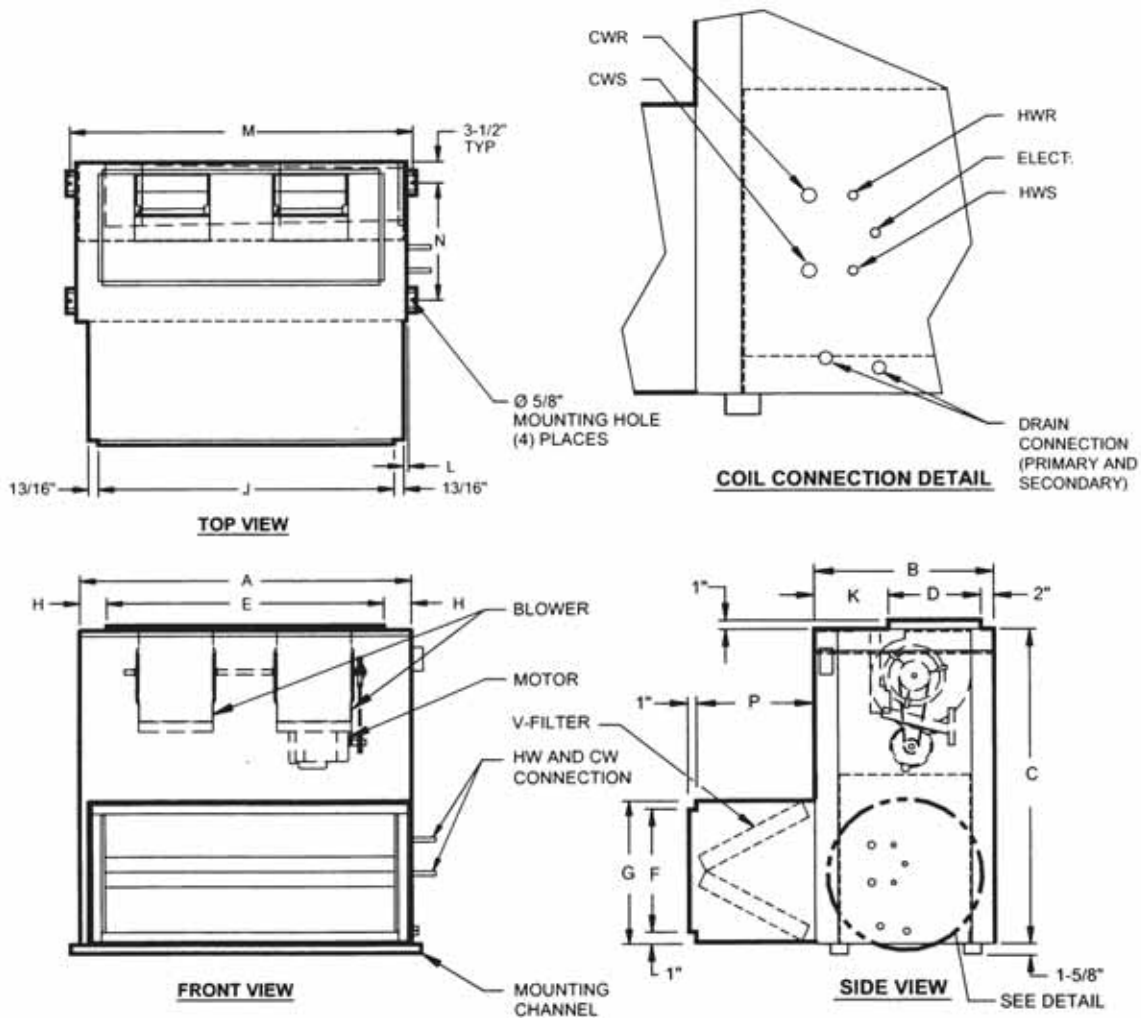

VERTICAL WITH ANGULAR FILTER 4,000 THRU 12,000 CFM														
MODEL	A	B	C	D	E	F	G	H	J	K	L	M	P	FILTER SIZE
40	57 1/4	27 1/4	54	18	48	22 9/16	25 1/8	4 5/8	48 1/8	7 1/4	1 3/8	59	1 3/16	(4) 20X25X2
50	71 1/4	27 1/4	54	20	54	22 9/16	25 1/8	8 5/8	62 1/8	5 1/4	2 1/2	73	1 3/16	(6) 20X20X2
60	85 1/4	27 1/4	60	20	60	22 9/16	25 1/8	12 11/16	72 5/8	5 1/4	1 3/8	87	1 3/16	(8) 20X20X2
80	85 1/4	27 1/4	67	24	72	30 9/16	30 1/8	6 5/8	76 1/2	1 1/4	1 3/8	87	1 7/8	(8) 20X25X2
100	105 1/4	27 1/4	67	24	90	30 9/16	30 1/8	7 5/8	102 7/8	1 1/4	1 3/8	107 1/4	1 7/8	(8) 20X25X2
120	116 1/4	34 1/4	83	28	90	30 9/16	30 1/8	13 1/8	104 3/8	4 1/4	1 3/8	118 1/4	1 7/8	(8) 20X25X2

Model BWVB & BXVB-40 thru 120 / BWVD & BXVD-40 thru 120 (B=Basic, D=Deluxe)

- Right-hand unit shown, left-hand unit opposite.
- Coil connections determined by facing the supply-air opening.
- Electrical junction box is located on the same side as the coil connections.
- Drain pan is powder-coated epoxy with a 1/4" thick closed-cell insulation and has 1" to 1 1/2" NPT primary and secondary drain connections.

MIXING BOXES FOR HORIZONTAL AND VERTICAL UNITS

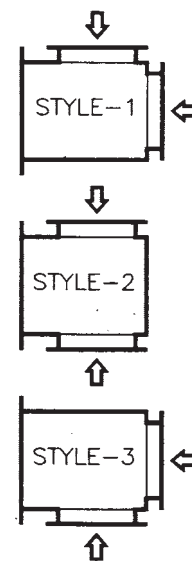
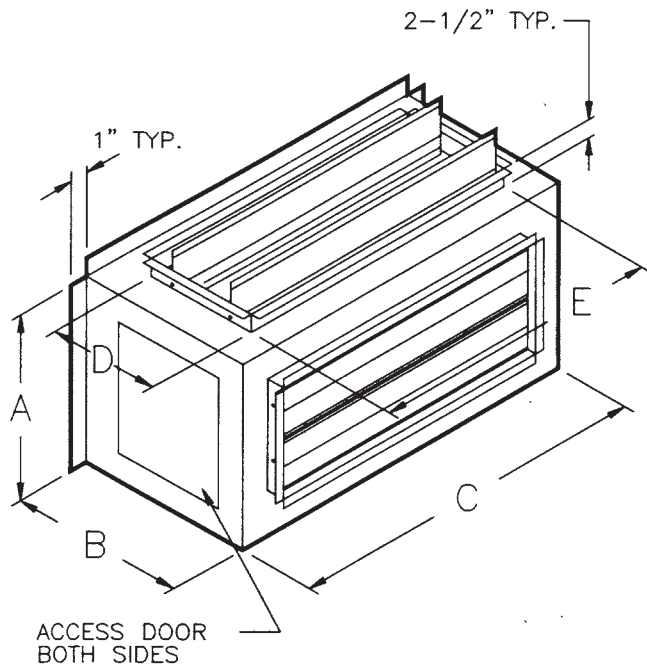

R. SIDE VIEW

TWO-POSITION ECONOMIZER MODULATING					
MODEL	A	B	C	D	E
08	17 1/2	18	18	12	14
12	17 1/2	18	23	12	18
16	17 1/2	18	29 11/16	12	24
20	17 1/2	18	29 11/16	12	24
30	22 9/16	18	37 11/16	14	32
40	22 9/16	22	49 3/16	18	45
50	22 9/16	22	62 3/16	18	58
60	22 9/16	22	72 11/16	18	68
80	29 9/16	22	76 11/16	18	72
100	30 9/16	22	103 1/16	18	99
120	30 9/16	22	104 3/4	18	99

- Heavy-gauge galvanized steel construction.
- Internally insulated with one-half inch, over three-pound density fiberglass.
- One-inch duct flange on damper openings.
- Dampers are centered in panel.
- Single, horizontal blade dampers with air seals on edge for positive closing, except double horizontal blade dampers.
- Furnished with crank arms and linkage rod for damper connection.
- Access doors on both sides.
- Connections may be made on either side (Linkage hardware motor and controls not included).
- Box attaches to return-air and outside-air duct flanges.
- Shipped separately for field installation.

HORIZONTAL INTEGRAL HEATER 800 THRU 3000 CFM (2 THRU 7.5 TONS)

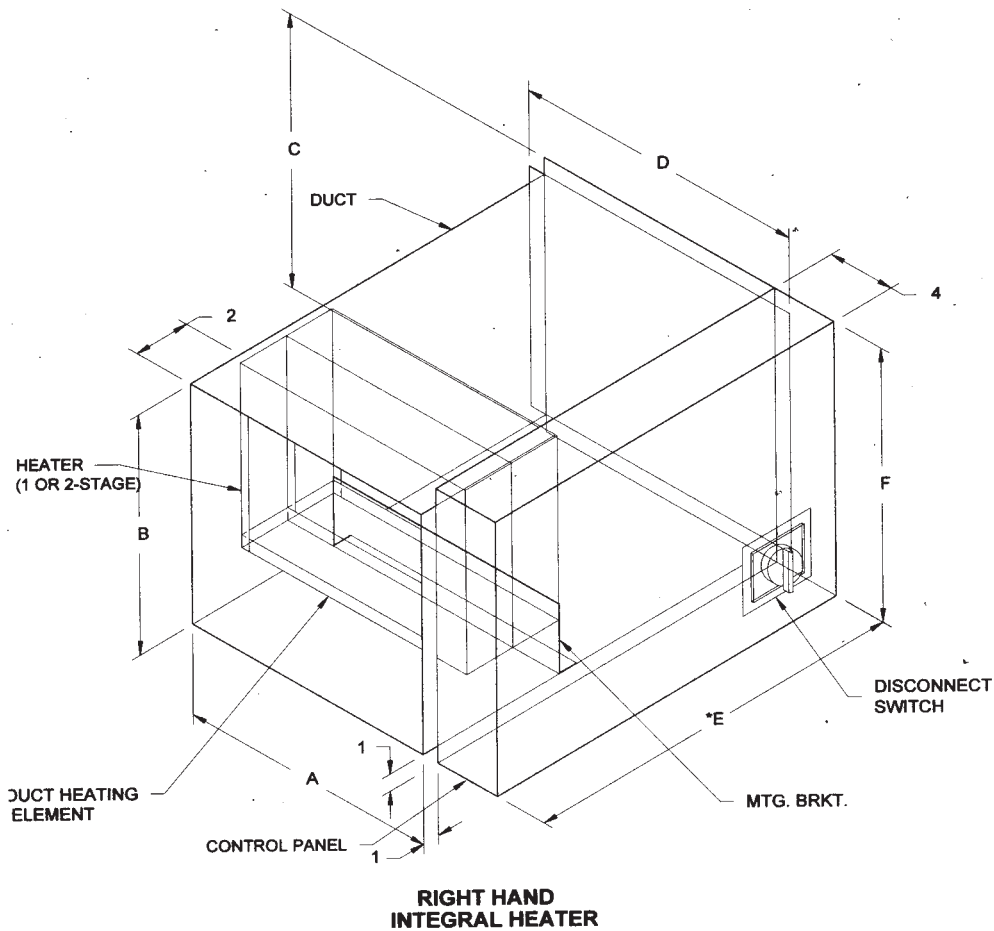

HORIZONTAL INTEGRAL HEATER - 800 THRU 3000 CFM						
MODEL	A	B	C	D	E (MIN.-MAX.)	F
08	9	12	13 7/8	10 7/8	18-28	14
12	14	12	13 7/8	15 7/8	18-28	14
16	14	12	13 7/8	15 7/8	18-28	14
20	16 1/4	14	15 7/8	18 1/8	16-26	16
30	19 1/4	16 1/2	18 3/8	21 1/8	18-22	18 1/2

- Right hand integral heater shown. Left hand integral heater opposite.
- “E” dimension varies based on electric heater ratings.
- “C” & “D” dimensions include flanges.

HORIZONTAL INTEGRAL HEATER 4000 THRU 12,000 CFM (10 THRU 30 TONS)

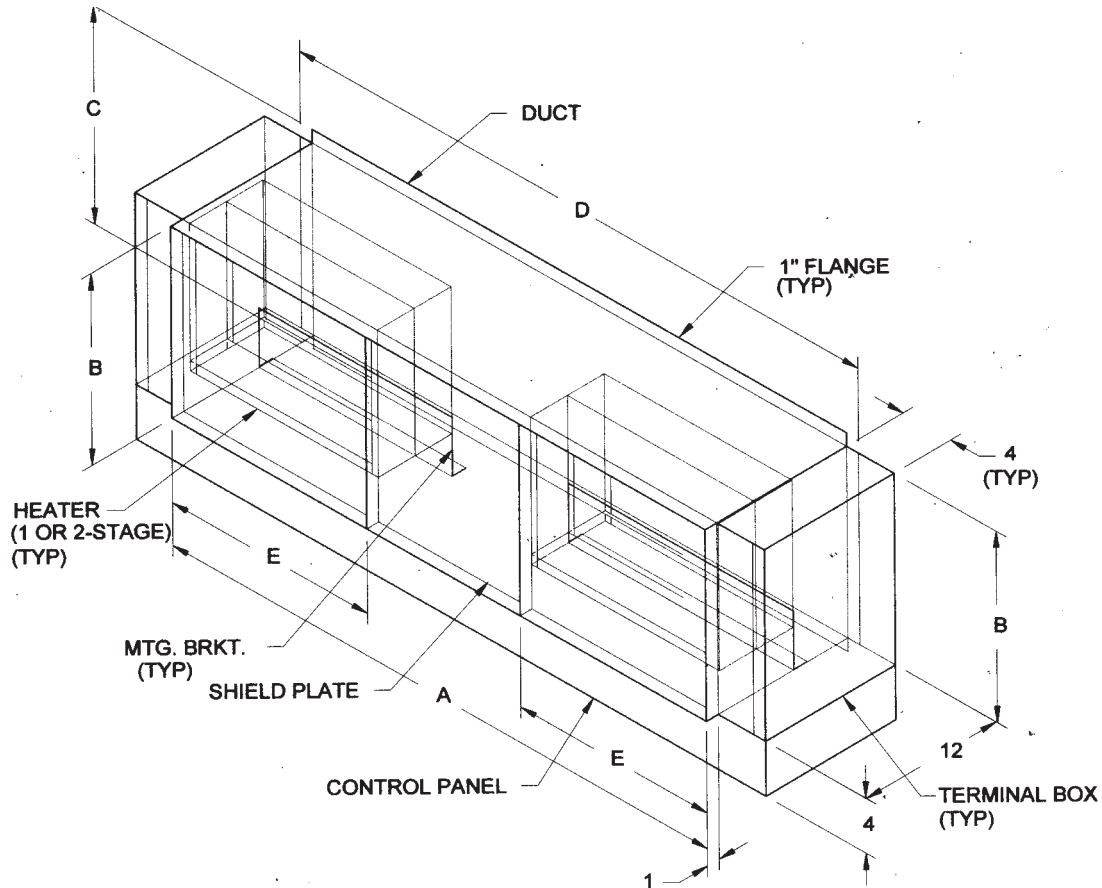

HORIZONTAL DUCT HEATER - 4000 THRU 12,000 CFM					
MODEL	A	B	C	D	E
40	45	14	15 7/8	46 7/8	16
50	45	14	15 7/8	46 7/8	16
60	55	16 1/2	18 3/8	56 7/8	19
80	55	16 1/2	18 3/8	56 7/8	19
100	55	16 1/2	18 3/8	56 7/8	19
120	55	16 1/2	18 3/8	56 7/8	19

- Right hand integral heater shown. Left hand integral heater opposite.
- “C” & “D” dimensions include flanges.

HORIZONTAL - BASIC & DELUXE

UNIT MEASURES and WEIGHTS - HORIZONTAL BASIC & DELUXE MODEL								
HORIZONTAL MODEL	DIMENSIONS - INCHES				DIMENSIONS - MILLIMETERS			
	HEIGHT	WIDTH	DEPTH	POUNDS	HEIGHT	WIDTH	DEPTH	KILOGRAMS
08	21	25	42	190	533	635	1067	86
12	21	31	42	200	533	787	1067	91
16	21	39	42	280	533	991	1067	127
20	24	39	42	300	610	991	1067	136
30	30	47	48	440	762	1194	1219	200
40	30	58	48	500	762	1473	1219	227
50	30	72	48	680	762	1829	1219	310
60	30	86	48	840	762	2184	1219	382
80	37	86	48	1080	940	2184	1219	490
100	37	105	48	1650	940	2667	1219	749
120	37	117	61	1990	940	2972	1549	905

VERTICAL - BASIC & DELUXE

UNIT MEASURES and WEIGHTS - VERTICAL BASIC & DELUXE MODEL								
VERTICAL MODEL	DIMENSIONS - INCHES				DIMENSIONS - MILLIMETERS			
	HEIGHT	WIDTH	DEPTH	POUNDS	HEIGHT	WIDTH	DEPTH	KILOGRAMS
08	48	25	30	260	1219	635	762	118
12	48	31	30	290	1219	787	762	132
16	48	39	30	370	1219	991	762	168
20	56	39	30	380	1422	991	762	173
30	62	47	30	600	1575	1194	762	273
40	56	58	30	620	1422	1473	762	282
50	56	72	30	850	1422	1829	762	386
60	62	86	30	1090	1575	2184	762	496
80	69	86	30	1360	1753	2184	762	619
100	69	106	30	1730	1753	2692	762	785
120	85	117	37	2076	2159	2972	940	944

MIXING BOXES

UNIT MEASURES and WEIGHTS - VERTICAL AND HORIZONTAL MIXING BOXES								
VERTICAL MODEL	DIMENSIONS - INCHES				DIMENSIONS - MILLIMETERS			
	HEIGHT	WIDTH	DEPTH	POUNDS	HEIGHT	WIDTH	DEPTH	KILOGRAMS
08	17 19/32	18 3/32	18	40	447	460	457	18
12	17 19/32	23 3/32	18	45	447	587	457	20
16	17 19/32	29 25/32	18	51	447	756	457	23
20	17 19/32	29 25/32	18	51	447	756	457	23
30	22 21/32	37 3/4	18	65	575	959	457	30
40	22 11/16	49 5/16	22	115	576	1253	559	52
50	22 11/16	62 5/16	22	140	576	1583	559	64
60	22 3/4	72 7/8	22	160	576	1851	559	73
80	30	76 7/8	22	175	762	1953	559	80
100	30 3/4	103 1/4	22	240	781	2623	559	109
120	30 3/4	104	22	260	781	2661	559	119

NOTE: Consult product catalog for certified dimensional data.
Weights and measures are based on air handlers units only add approximately 20% for packaging /crating.

CHILLED AND HOT WATER PIPING INSTRUCTIONS

Purpose: This data is intended to explain piping arrangements for chilled and hot water coils to the correct inlet and outlet locations.

Two-Pipe Coils: have one inlet and outlet. Air Handlers may have one to ten rows on each unit. The coil may be 100% chilled water, 100% hot water, or with the addition of a pipe sensor changeover control, it may use chilled water when the chiller is operating or hot water when the boiler is operating. A two-pipe system allows for the chiller or boiler to operate independently, one at a time. The pipe sensor must be clamped onto the supply water line as close to the incoming water source as possible. The purpose of the pipe sensor is to sense the water temperature at its' set point of approximately 88°F. The pipe sensor will change the thermostat control from the cooling mode to the heating mode and vice versa.

The inlet is always at the bottom of the coil and the outlet is always at the top of the coil. All coils are piped so that the inlet is always on the row farthest downstream from the incoming air (See diagram 1).

All coils have one or more circuits. Circuits are added to reduce the water pressure drop to an acceptable level (usually 10-ft. H₂O pressure drop or less). Due to the various circuit options available, the inlet and outlet may change position, making the inlet and outlet locations vary.

Four-Pipe Coils: have a dedicated, chilled-water coil, and a dedicated hot-water coil; each with its' own inlet and outlet, equaling four pipes. USA Coil & Air coils use a common tube sheet for four-pipe coils. Example: A four-row, chilled-water coil and a one-row, hot-water coil would use a five-row coil with four rows for chilled-water and one row for hot-water. Normally the one-row, hot-water coil is in the reheat position or downstream from the cooling coil. The hot-water coil may also be ordered in the preheat position or upstream from the chilled-water coil. The controls are wired so that either the chilled-water coil is operating or the hot-water coil is operating, but not both at the same time. When the conditioned space thermostat is satisfied, both the chilled and hot-water control valves are deactivated. The same rule applies for inlet and outlet locations as explained above in "Two-Pipe Coils". (See diagram 2.) Each chilled and hot-water coil is controlled individually so a pipe sensor is not required.

Two-Pipe Coil Diagrams 1 (Two) Pipe Coils (Right Hand Shown, Left Hand Opposite)

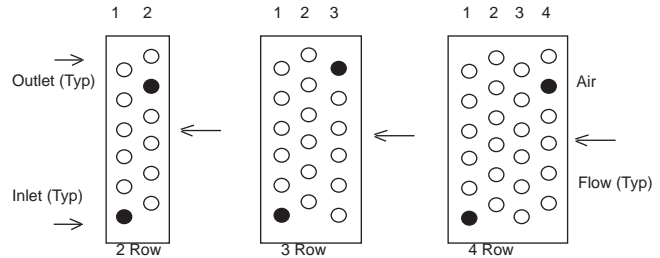

Four-Pipe Coil Diagrams 2 (Four) Pipe Coils (Right Hand Shown, Left Hand Opposite)

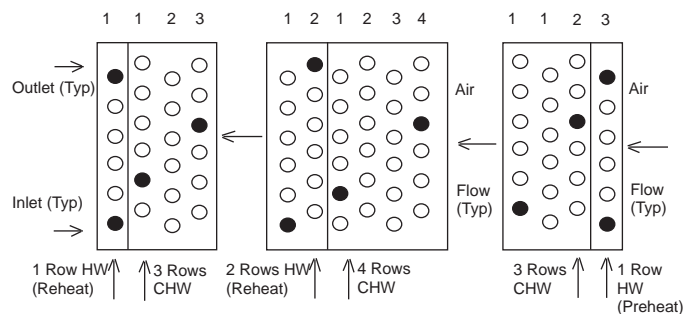

STANDARD REHEAT POSITION

SPECIAL ORDER
(Heating coil located in the preheat position)

Because of the variations of the circuiting available, the location of the inlet and outlet connections may vary up and down. However, always use the following rule to be correct. **The inlet is always the lower connection and the farthest away from the entering-air-side. The outlet connection is always the higher connection the closest to the entering-air-side.**



HVAC and Industrial Coils

Fast shipment on all types of HVAC Coils to include: steam, hot water, chilled water, DX, and condenser replacement for any existing coil available in 5 or 10 work days.

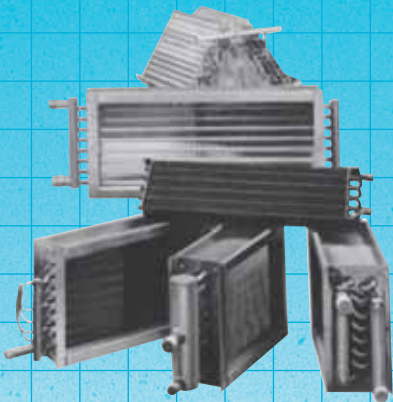

Stock Cooling and Heating Coils

Immediate shipment of Chilled Water and DX Cooling Coils for Vertical or Horizontal Airflow. Also available are 1 row and 2 row Flanged Hot Water/Steam Coils from 6 x 12 to 30 x 60.



Chillers and Water Cooled Condensers

Immediate shipment of chillers (7½ to 150 ton) and Water Cooled Condensers (5 to 150 ton). Replacements and special configurations and construction available.

USA Coil & Air. **An outstanding product line *plus*, service, availability and quality.**

Replacement Tube Bundles and Heat Exchangers

5 and 10 working day shipments available for most U-Tube and Straight-Tube bundles constructed of copper. Cupronickel, carbon steel, brass and stainless steel also available.

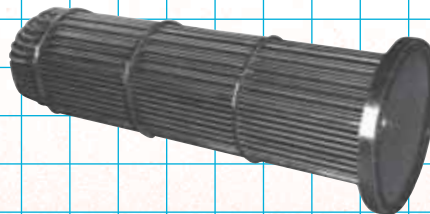

Central Station Air Handling Units

Fast shipment on a complete line of Horizontal and Vertical Units. Cooling up to 50,000 CFM and heating up to 60,000 CFM. Options include forward curved or airfoil fans, variable inlet vanes, special coils, filter sections and mixing box also are available.

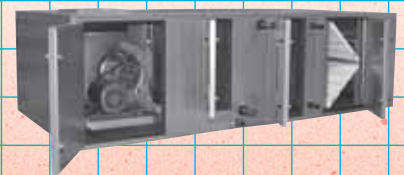

Represented by:

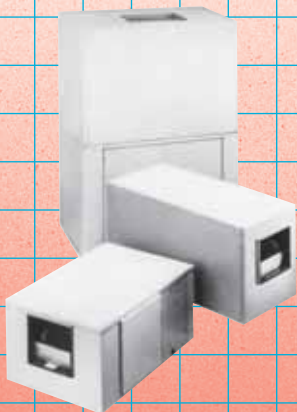

Belt Drive Fan-Coil Units

Immediate shipment available on nominal 2 ton to 20 ton Horizontal or Vertical Units for either Chilled Water or Refrigerant Cooling. Options include hot water or steam heating, mixing box and discharge grills.